

平成15年12月16日開示分

網機能情報提供対象装置に関する情報開示

- ユーザ網インタフェース -

A D S L 技術開示資料

平成 1 5 年 8 月
西日本電信電話株式会社

本資料の内容は、機能追加などにより追加・変更されることがあります。
なお、内容についての問い合わせは、下記宛にお願い致します。

西日本電信電話株式会社
ブロードバンド推進本部
B B アクセスサービス部サービス開発グループ

adsl-tech@ml.hq.west.ntt.co.jp

まえがき

このADSL技術開示資料は、西日本電信電話株式会社（以下、NTT西日本）と接続する端末機器のインタフェース条件について説明したもので、端末機器等を設計、準備する際の参考となる技術的情報を提供するものです。既にサービス提供中の情報については、技術参考資料（フレッツ・シリーズ）を参照して下さい。技術参考資料は、ホームページ（<http://www.ntt-west.co.jp>）及び情報ステーションにて閲覧できます。

本資料は、既にフレッツ・ADSLで使用されているG.992.1 Amd.1 Annex Iをベースに説明したものです。よって、ITU-T勧告G.992.1の本文と合わせて参考いただく情報とさせていただきます。

なお、ITU-T等で標準化作業中の方式を含みますが、標準化された後は標準化技術として置き換わります。

また、本資料は、NTT西日本のサービス提供を保証するものではありません。

フレッツ・ADSLに接続される端末設備が必ず適合しなければならない技術的条件は、「端末設備等の接続の技術的条件」又は「端末設備等規則」（昭和60年郵政省令31号）に定められています。

今後、本資料は、予告なく変更される場合があります。

G.992.1 ANNEX Q
PROPRIETARY EXTENSION TO G.992.1 ANNEX I

Attached is proposed text for G.992.1 Annex Q (Quad spectrum), a proprietary extension to G.992.1 Annex I to extend the data rate beyond 32 Mbit/s on short loops by way of:

- Increased bandwidth → increased number of subcarriers, NSC=1024 (used subcarriers up to 869)
- Increased bit loading, beyond 15 bits/bin
- Extended framing → $S=1/2n$, with support for $n = 1$ to 4

The attached text is the approved draft text for Annex I, marked up with revision control to show the changes necessary to support the additional functionality. Editorial changes such as replacing “Annex I” with “Annex Q” are not shown with revision control.

ANNEX Q

Specific requirements for an ADSL system to support data rates greater than 32 Mbit/s on short loops operating in the same cable as ISDN as defined in ITU-T Recommendation G.961 Appendix III

Q.1 Scope

This annex describes those specifications that are unique to an ADSL system coexisting in the same binder as TCM-ISDN as defined Recommendation G.961 Appendix III. The subclauses in this annex provide supplementary and replacement material to the clauses in the main body. The nature of the material is parenthetically indicated in the subclause heading. The modifications described in this annex allow a performance improvement from the ADSL system specified in Annex C for short loops in an environment coexisting with TCM-ISDN in the same cable. Specifically, this Annex specifies extensions to downstream bandwidth, framing modes, and maximum bit loading to support downstream data rates greater than 32 Mbit/s. This annex also defines those parameters of this ADSL system that have been left undefined in the main body of this Recommendation. It is recommended that ADSL system implementing Annex Q also implements Annex C.

Q.2 Definitions

Bitmap-F _C	ATU-R transmitter bitmap under TCM-ISDN FEXT noise generated at ATU-C
Bitmap-F _R	ATU-C transmitter bitmap under TCM-ISDN FEXT noise generated at ATU-R
Bitmap-N _C	ATU-R transmitter bitmap under TCM-ISDN NEXT noise generated at ATU-C
Bitmap-N _R	ATU-C transmitter bitmap under TCM-ISDN NEXT noise generated at ATU-R
Dual Bitmap FEXT Bitmap	The Dual Bitmap method has dual bit rates under the FEXT and NEXT noise from TCM-ISDN Similar to the Dual Bitmap method however transmission only occurs during FEXT noise from TCM-ISDN
FEXT _C duration	TCM-ISDN FEXT duration at ATU-C estimated by the ATU-R
FEXT _C symbol	DMT symbol transmitted by ATU-R during TCM-ISDN FEXT
FEXT _R duration	TCM-ISDN FEXT duration at ATU-R estimated by the ATU-C
FEXT _R symbol	DMT symbol transmitted by ATU-C during TCM-ISDN FEXT
Hyperframe	5 Superframes structure which synchronized TTR
NEXT _C duration	TCM-ISDN NEXT duration at ATU-C estimated by the ATU-R
NEXT _C symbol	DMT symbol transmitted by ATU-R during TCM-ISDN NEXT
NEXT _R duration	TCM-ISDN NEXT duration at ATU-R estimated by the ATU-C
NEXT _R symbol	DMT symbol transmitted by ATU-C during TCM-ISDN NEXT
NSC	The highest subcarrier index that can be used for downstream transmission (i.e., the subcarrier index corresponding to the Nyquist frequency) For example, NSC = 256 for a downstream channel using the frequency band up to 1.104MHz; NSC = 512 for a downstream channel using the frequency band up to 2.208MHz.
N _{SWF}	Sliding Window frame counter
Subframe	10 consecutive DMT symbols (except for sync symbols) according to TTR timing
TTR	TCM-ISDN Timing Reference
TTR _C	Timing reference used in ATU-C
TTR _R	Timing reference used in ATU-R
UI	Unit Interval

Q.3 Reference Models

Q.3.1 ATU-C transmitter reference model (replaces figures in 5.1)

See Figure Q.1 and Figure Q.2.

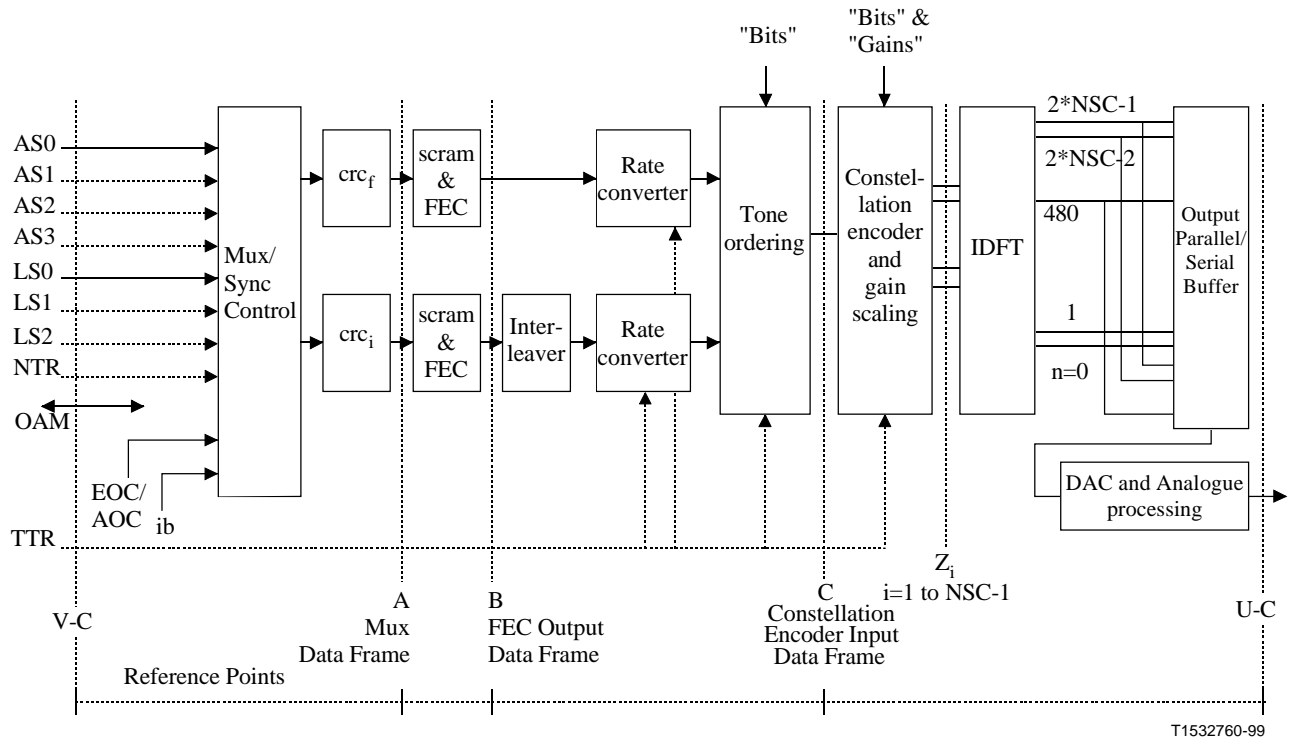

NOTE – The TTR may be generated in ATU-C without being provided from the TCM-ISDN clock.

Figure Q.1/G.992.1 – ATU-C transmitter reference model for STM transport

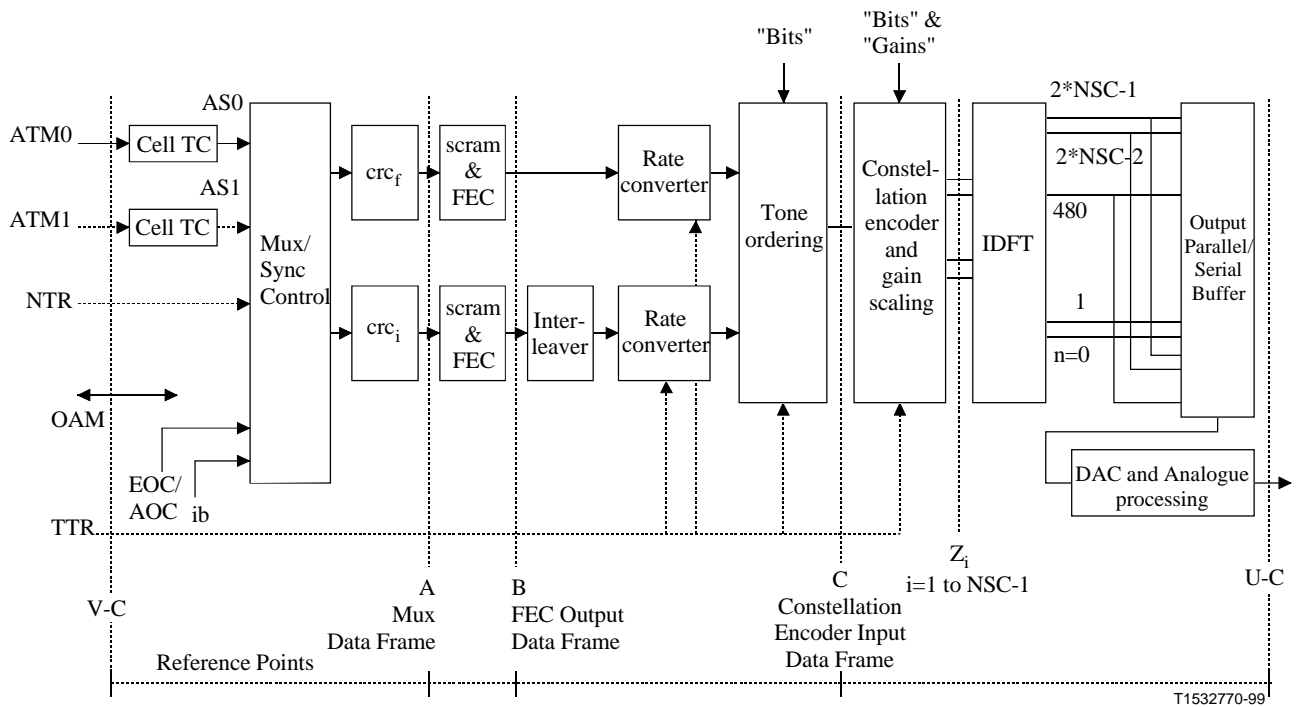

NOTE – The TTR may be generated in ATU-C without being provided from the TCM-ISDN clock.

Figure Q.2/G.992.1 – ATU-C transmitter reference model for ATM transport

Q.3.2 ATU-R transmitter reference model (replaces figures in 5.2)

See Figure Q.3 and Figure Q.4.

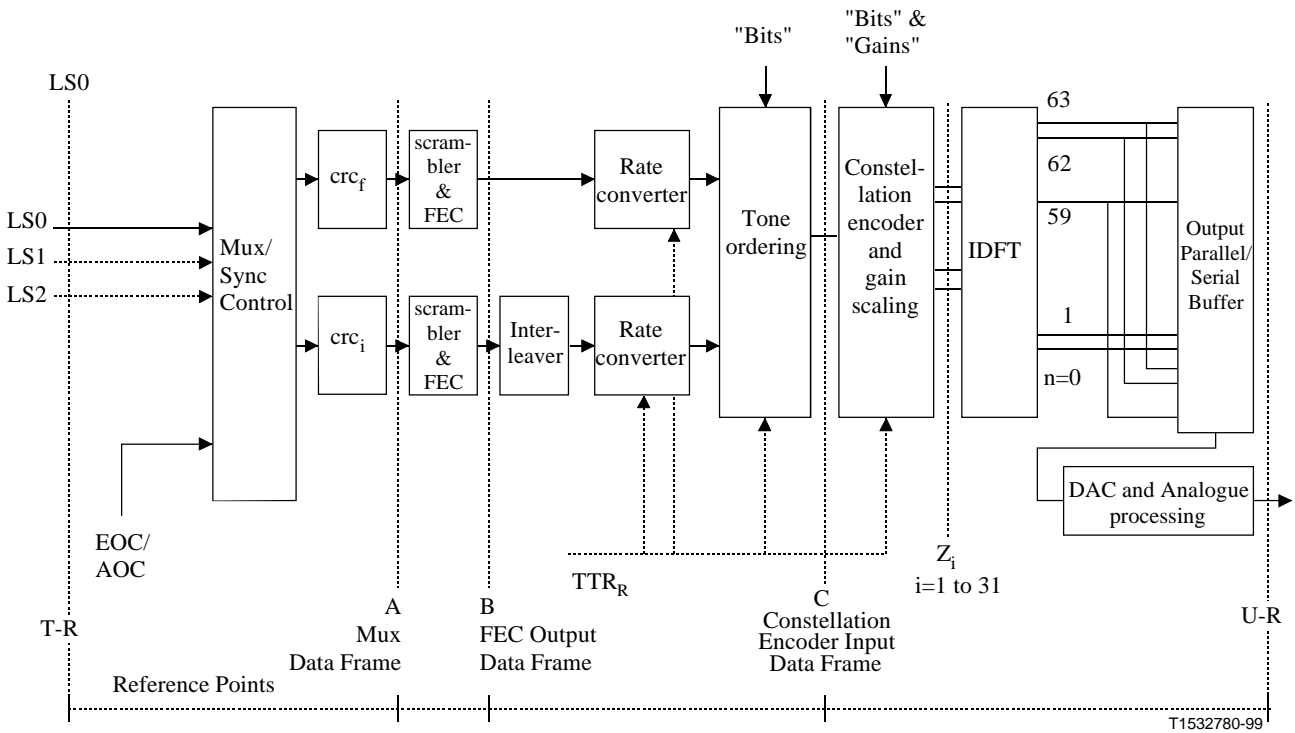

NOTE – The TTR_R shall be generated in ATU-R from the received TTR_C signal, and it is locked to 690 periods of upstream sampling clock (276 kHz).

Figure Q.3/G.992.1 – ATU-R transmitter reference model for STM transport

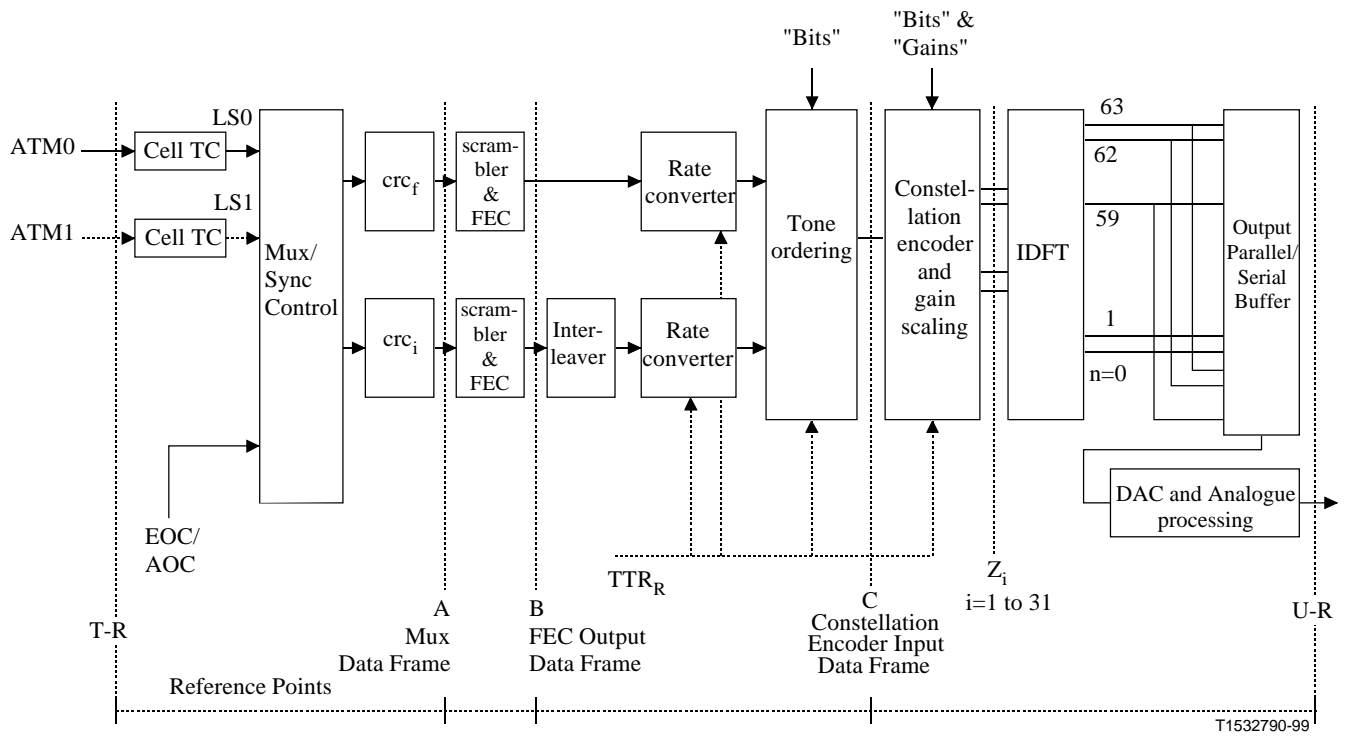

NOTE – The TTR_R shall be generated in ATU-R from the received TTR_C signal, and it is locked to 690 periods of upstream sampling clock (276 kHz).

Figure Q.4/G.992.1 – ATU-R transmitter reference model for ATM transport

Q.3.3 ATU-C/R transmitter timing model (replacement for 5.3)

Q.3.3.1 TCM-ISDN crosstalk timing model (new)

Figure Q.5 shows the timing chart of the crosstalk from TCM-ISDN.

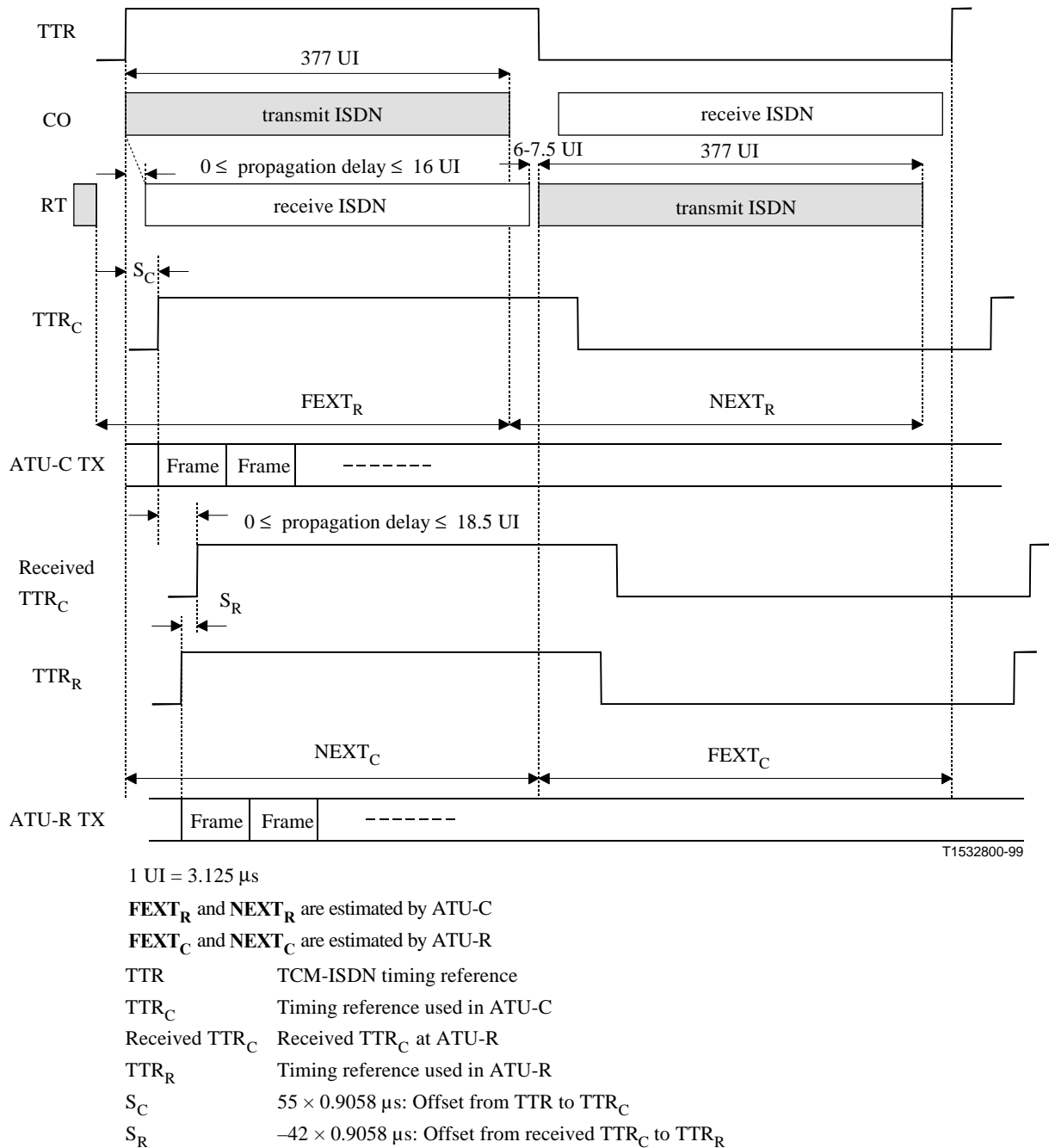

Figure Q.5/G.992.1 – Timing chart of the TCM-ISDN crosstalk

The data stream of TCM-ISDN is transmitted in TTR period. CO transmits the stream in the first half of the TTR period and RT transmits in the second half of the TTR period. ATU-C receives NEXT noise from the ISDN in the first half of the TTR period and FEXT noise from the ISDN in the second half of the TCM-ISDN period. On the other hand, ATU-R receives FEXT noise from the ISDN in the first half of the TTR period and NEXT noise from the ISDN in the second half of the TTR period.

As defined in Q.7.6.2 and Q.7.8.3, the ATU-C shall estimate the $FEXT_R$ and $NEXT_R$ duration at ATU-R, and the ATU-R shall estimate $FEXT_C$ and $NEXT_C$ duration at ATU-C taking propagation delay on the subscribe line into consideration.

The ATU-C shall transmit any symbols by synchronizing with the TTR_C . The ATU-R shall transmit any symbols synchronizing with the TTR_R generated from received TTR_C .

Q.3.3.2 Sliding window (new)

Figure Q.6 shows the timing chart of the transmission for the Annex Q downstream at ATU-C.

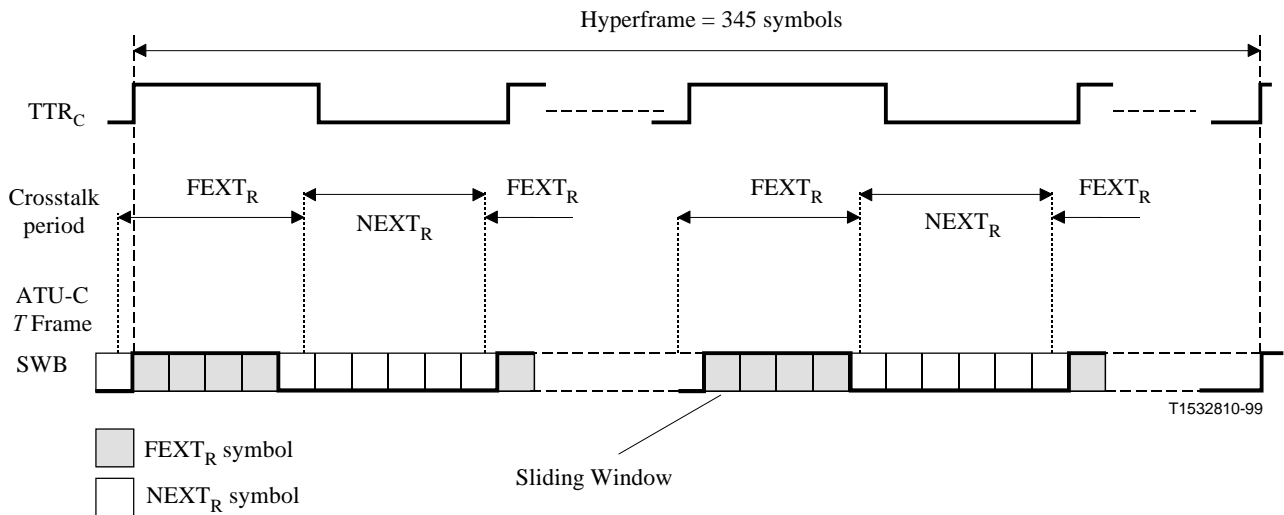

Figure Q.6/G.992.1 – Sliding window for downstream symbols

The Sliding Window defines the transmission symbols under the crosstalk noise environment synchronized to the period of TTR. The $FEXT_{C/R}$ symbol represents the symbol completely inside the $FEXT_{C/R}$ duration. The $NEXT_{C/R}$ symbol represents any symbol containing the $NEXT_{C/R}$ duration. Thus, there are more $NEXT_{C/R}$ symbols than $FEXT_{C/R}$ symbols.

The ATU-C decides which transmission symbol is $FEXT_R$ or $NEXT_R$ symbol according to the sliding window and transmits it with the corresponding bit table. Similarly, the ATU-R decides the transmission symbol is a $FEXT_C$ or $NEXT_C$ and transmits it with the corresponding bit table. Although the phase of the sliding window is asynchronous with $TTR_{C/R}$, the pattern is fixed to the 345 frames of the hyperframe.

Q.3.3.3 ATU-C Symbol Synchronization to TTR (new)

345 symbols are 34 cycles with cyclic prefix of TTR_C (or 32 cycles of TTR_C without cyclic prefix). This implies a PLL lock at the ATU-R.

Q.3.3.4 Dual Bitmap switching (new)

The ATU-C transmits $FEXT_R$ symbols using Bitmap- F_R (in $FEXT_R$ duration), and transmits $NEXT_R$ symbols using Bitmap- N_R (in $NEXT_R$ duration) according to the result of initialization. The ATU-R transmits $FEXT_C$ symbols using Bitmap- F_C (in $FEXT_C$ duration), and transmits $NEXT_C$ symbols using Bitmap- N_C (in $NEXT_C$ duration) in the same manner.

The ATU-C shall have the capability to disable Bitmap- N_C and Bitmap- N_R (see Q.4.5 and Q.5.3).

Q.3.3.5 Loop timing at ATU-R (new)

The phase relation between received symbol and transmitted symbol of ATU-R at the reference point U-R shall meet the phase tolerances as shown in Figure Q.7.

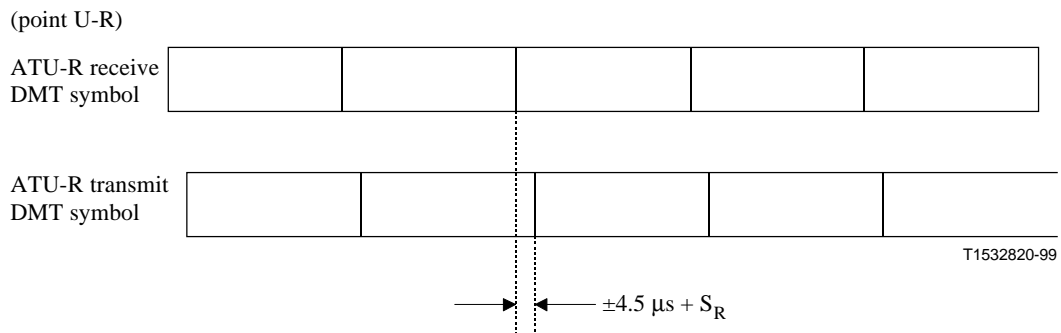

Figure Q.7/G.992.1 – Loop timing for ATU-R

Q.4 ATU-C functional characteristics (pertains to clause 7)

Q.4.1 STM transmission protocols specific functionality (pertains to 7.1)

Q.4.1.1 ATU-C input and output V interface for STM transport (replaces figure in 7.1.1)

See Figure Q.8.

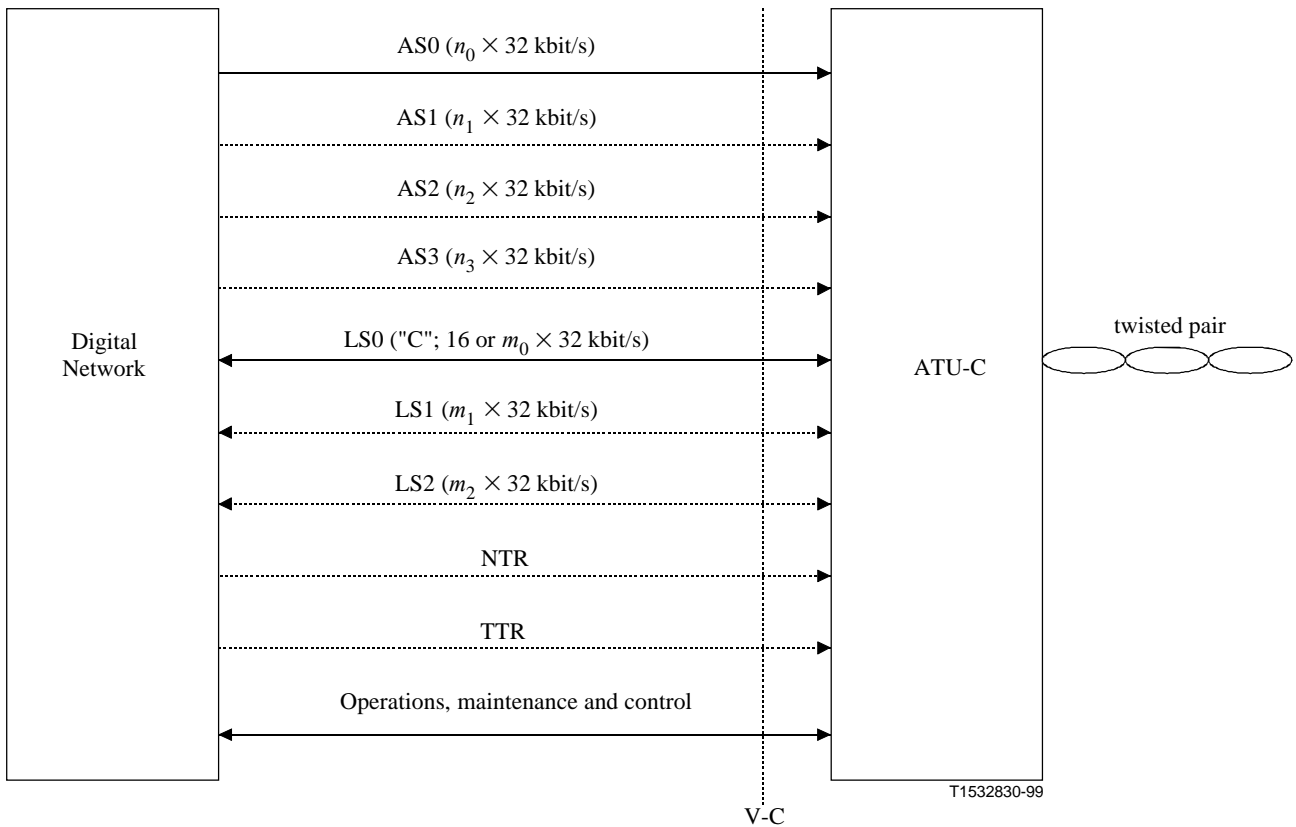

NOTE 1 – Optional bearer channels (both duplex and simplex) and features are shown with dotted lines.
 NOTE 2 – TTR may be generated in the ATU-C without being provided from the V-C reference point.

Figure Q.8/G.992.1 – ATU-C functional interfaces for STM transport at the V-C reference point

Q.4.1.2 Payload transfer delay (supplements 7.1.4)

Since Annex Q uses a rate converter, the maximum payload transfer delay is longer than specified values in 7.1.4. The additional one-way transfer delay due to the rate converters shall be less than 1.7 ms for fast data and 13 ms for interleaved data.

Q.4.2 ATM transmission protocols specific functionalities (pertains to 7.2)

Q.4.2.1 ATU-C Input and Output V interface for ATM transport (replaces figure in 7.2.1)

See Figure Q.9.

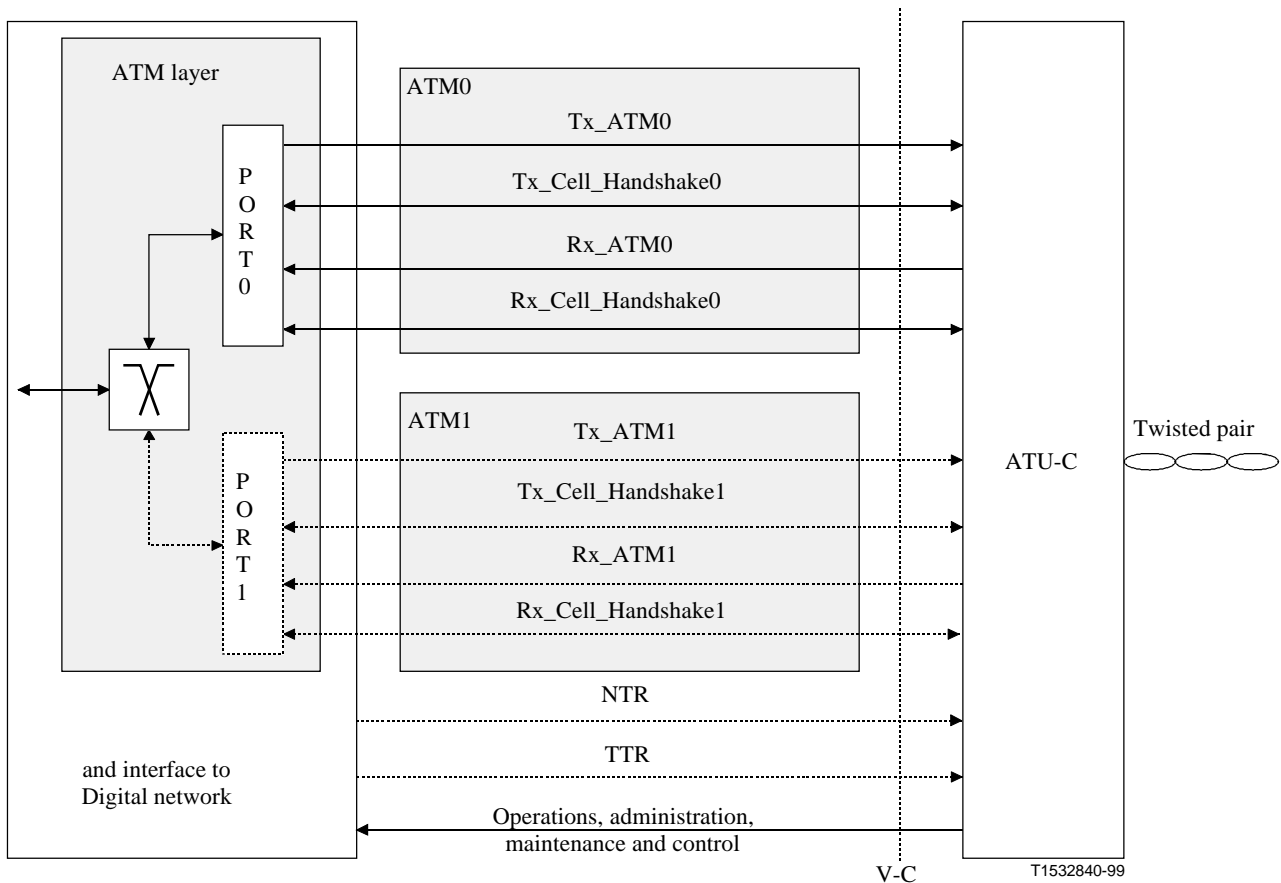

NOTE – TTR can be generated in the ATU-C without being provided from the V-C reference point.

Figure Q.9/G.992.1 – ATU-C functional interfaces to the ATM layer at the V-C reference point

Q.4.2.2 Payload transfer delay (supplements 7.2.2)

Since Annex Q uses a rate converter, the maximum payload transfer delay is longer than specified values in 7.2.2. The additional one-way transfer delay due to the rate converters shall be less than 1.7 ms for fast data and 13 ms for interleaved data.

Q.4.3 Framing (pertains to 7.4)

Q.4.3.1 Superframe structure (supplements 7.4.1.1)

Since the rate converter reorders the user data and overhead bit-level data to create hyperframes, the input data frames to the constellation encoder are different than those defined in 7.4.1.1.

Q.4.3.2 Hyperframe structure (replaces 7.4.1.3)

Annex Q uses the hyperframe structure shown in Figure Q.10. Figure Q.10 shows the phase relationship between the TTR_C and the hyperframe at the point U-C. Each hyperframe is composed of 5 superframes, which are numbered from 0 to 4. In order to indicate the boundary of the hyperframe, the inverse synch symbol is used for the 4th superframe (SPF#3), which is generated from a tone-by-tone 180-degree phase reversal of the synchronization symbol (see Q.4.7.1) except for the pilot tone.

The bit-level data stream from the rate-converter is extracted according to the size of $Bitmap-F_R$ and $Bitmap-N_R$ using the Sliding Window (see Q.3.3.2).

In order to make the bit rate to be a multiple of 32 kbit/s, the dummy bits are inserted at the end of hyperframe by the

rate converter (see Q.4.4.2). The hyperframe is composed of 345 DMT symbols, numbered from 0 to 344. Each symbol is assigned as FEXT_R or NEXT_R symbol in a FEXT_R or NEXT_R duration (see Q.2), and the following numerical formula gives the information which duration N_{dm_t}-th DMT symbol belongs to at ATU-C transmitter (see Figure Q.11).

For N_{dm_t} = 0, 1, ..., 344

$$S = 272 \times N_{dm_t} \bmod 2760$$

if { (S + 271 < a) or (S > a + b) }	then FEXT _R symbol
else	then NEXT _R symbol

where a = 1243, b = 1461

Thus, 128 DMT symbols are allocated in the FEXT_R duration, and 217 DMT symbols are allocated in the NEXT_R duration. The symbols are composed of:

FEXT_R symbol:

Number of symbol using Bitmap-F _R	= 126
Number of synch symbol	= 1
Number of inverse synch symbol	= 1

NEXT_R symbol:

Number of symbol using Bitmap-N _R	= 214
Number of synch symbol	= 3

During FEXT Bitmap mode, the ATU-C shall transmit only the pilot tone in NEXT_R symbols.

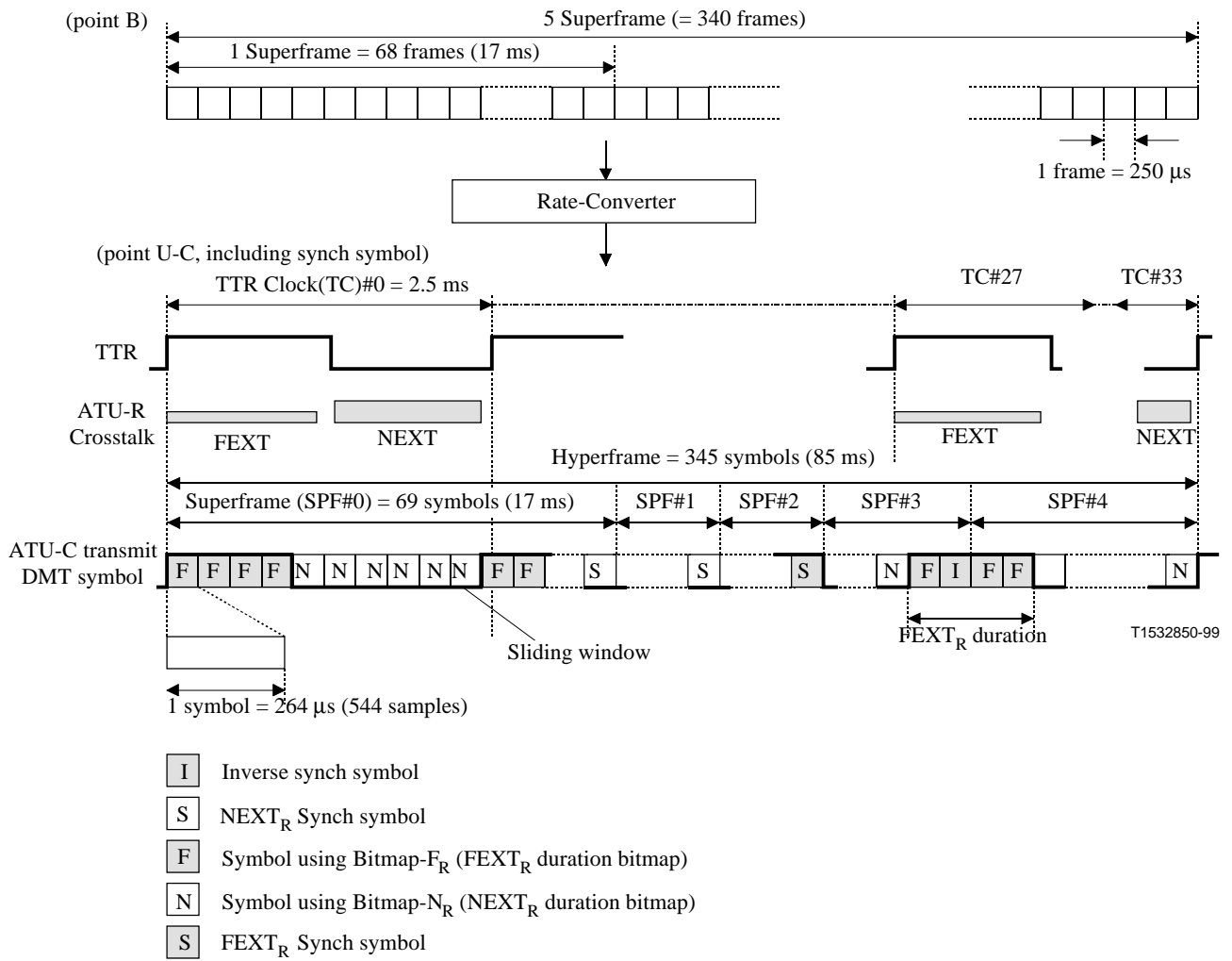

Figure Q.10/G.992.1 – Hyperframe structure for downstream

TTR_C

0	0	1	2	3	4	5	6	7	8	9	
1	10	11	12	13	14	15	16	17	18	19	
2	20	21	22	23	24	25	26	27	28	29	
3	30	31	32	33	34	35	36	37	38	39	40
4		41	42	43	44	45	46	47	48	49	50
5		51	52	53	54	55	56	57	58	59	60
6	61	62	63	64	65	66	67	SS	69	70	
7	71	72	73	74	75	76	77	78	79	80	
8	81	82	83	84	85	86	87	88	89	90	
9	91	92	93	94	95	96	97	98	99	100	101
10	101	102	103	104	105	106	107	108	109	110	111
11		112	113	114	115	116	117	118	119	120	121
12		122	123	124	125	126	127	128	129	130	131
13	132	133	134	135	136	SS	138	139	140	141	
14	142	143	144	145	146	147	148	149	150	151	
15	152	153	154	155	156	157	158	159	160	161	
16	162	163	164	165	166	167	168	169	170	171	172
17		173	174	175	176	177	178	179	180	181	182
18		183	184	185	186	187	188	189	190	191	192
19		193	194	195	196	197	198	199	200	201	202
20	203	204	205	SS	207	208	209	210	211	212	
21	213	214	215	216	217	218	219	220	221	222	
22	223	224	225	226	227	228	229	230	231	232	
23	233	234	235	236	237	238	239	240	241	242	243
24		244	245	246	247	248	249	250	251	252	253
25		254	255	256	257	258	259	260	260	262	263
26		264	265	266	267	268	269	270	271	272	273
27	274	ISS	276	277	278	279	280	281	282	283	
28	284	285	286	287	288	289	290	291	292	293	
29	294	295	296	297	298	299	300	301	302	303	
30	304	305	306	307	308	309	310	311	312	313	314
31		315	316	317	318	319	320	321	322	323	324
32		325	326	327	328	329	330	331	332	333	334
33		335	336	337	338	339	340	341	342	343	SS

ISS Inverse synch symbol

SS FEXT_R Synch symbol

.SS NEXT_R synch symbol

FEXT_R data symbol

NEXT_R data symbol

T1535330-00

Figure Q.11/G.992.1 – Symbol pattern in a hyperframe with cyclic prefix – Downstream

Q.4.3.3 Subframe Structure (replaces 7.4.1.4)

A subframe is 10 consecutive DMT symbols (except for synch symbols) as shown in Table Q.1. The 34 subframes form a hyperframe.

Table Q.1/G.992.1 – Subframe (downstream)

Subframe No.	DMT symbol No.	Note
0	0-9	
1	10-19	
2	20-29	
3	30-39	
4	40-49	
5	50-59	
6	60-70	#68 is Synch Symbol
7	71-80	
8	81-90	
9	91-100	
10	101-110	
11	111-120	
12	121-130	
13	131-141	#137 is Synch Symbol
14	142-151	
15	152-161	
16	162-171	
17	172-181	
18	182-191	
19	192-201	
20	202-212	#206 is Synch Symbol
21	213-222	
22	223-232	
23	233-242	
24	243-252	
25	253-262	
26	263-272	
27	273-283	#275 is Inverse Synch Symbol
28	284-293	
29	294-303	
30	304-313	
31	314-323	
32	324-333	
33	334-344	#344 is Synch Symbol

Q.4.3.4 Reduced overhead framing with merged fast and sync bytes (modifies 7.4.3.2)

In $S=1/2n$ framing mode (see §Q.4.9), there are n Sync bytes per symbol time. The contents of the Sync bytes is the same as in regular framing except that it repeats at n times the rate causing the superframe to be $68/n$ symbols in length. The contents of the sync bytes are shown in Table 7-6/G.992.1. In $S=1/2n$ framing mode, “Frame Number” in column 1 in Table 7-6/G.992.1 is replaced by “Sync Byte Index Number”.

As a result of the increase in superframe rate, the superframe contents is carried more frequently. For the case when $N=2$, the EOC and AOC bandwidth doubles, thereby transferring actual messages at twice the rate. The CRC byte is carried twice as frequently and therefore the maximum error rate rises from just over 58 per second to 117 per second. Where the duration of an error condition is measured, this needs to be taken into consideration. The indicator bits are also sent twice as often, which needs to be taken into consideration for statistics collection.

Q.4.4 Dual Bitmapping and Rate Conversion (replaces 7.15)

The functions of the rate converter (see Q.4.4.2), tone ordering (see Q.4.6), constellation encoding, and gain scaling shall use one of two bitmaps stored in the ATU. This method is called the dual bitmap.

Q.4.4.1 Dual Bitmap (new)

The Dual Bitmap method has individual bit rates under the FEXT and NEXT noise, and this needs an additional bit and gain table, $\{b_i, g_i\}$, and ordered bit table, b'_i , for the tone ordering. The dual bitmaps are switched synchronized with the sliding window pattern of NEXT/FEXT symbols. The number of bits and the relative gains to be used for every tone are calculated in the bit loading algorithm during the initialization sequence, and transmitted in R-B&G.

Q.4.4.2 Rate Converter (new)

The rate converter buffering changes the data frame boundaries between the reference points B and C according to Bitmap-F_R, Bitmap-N_R and the Sliding Window. Two independent rate converters are prepared for fast data and interleaved data. The amount of fast and interleaved data in Bitmap-F_R and Bitmap-N_R shall be calculated with the following formulae and illustrated in Figure Q.12:

If $t_{Rf} \leq n_{Rmax}$:

$$\begin{aligned} n_{Rf} &= t_{Rf} \\ n_{Ri} &= n_R - n_{Rf} \\ f_{Rf} &= t_{Rf} \\ f_{Ri} &= f_R - f_{Rf} \end{aligned}$$

If $t_{Rf} > n_{Rmax}$:

$$\begin{aligned} n_{Rf} &= n_{Rmax} \\ n_{Ri} &= 0 \\ f_{Rf} &= \begin{cases} f_{Rf4} = \left\lfloor \frac{t_{Rf} \times 10 - n_{Rf} \times 6}{4} \right\rfloor \\ f_{Rf3} = \left\lfloor \frac{t_{Rf} \times 10 - n_{Rf} \times 7}{3} \right\rfloor \end{cases} \\ f_{Ri} &= \begin{cases} f_{Ri4} = f_R = f_{Rf4} \\ f_{Ri3} = f_R - f_{Rf3} \end{cases} \end{aligned}$$

Where:

- t_{Rf} is the number of allocated bits in one frame for fast bytes at the reference point B.
- t_{Ri} is the number of allocated bits for interleaved bytes at the reference point B.
- n_{Rf} and n_{Ri} are the numbers of fast bits in Bitmap-F_R and Bitmap-N_R, respectively.
- f_{Rf3} is the number of fast bits in Bitmap-F_R if the subframe (see Q.4.3.3) contains 3 Bitmap-F_R except for synch symbols.
- f_{Rf4} is the number of fast bits in Bitmap-F_R if the subframe contains 4 Bitmap-F_R except for synch symbols.
- f_{Ri} and n_{Ri} are the numbers of interleaved bits in Bitmap-F_R and Bitmap-N_R, respectively.
- n_R is the number of total bits in Bitmap-N_R, which is specified in the B&G tables.

During FEXT Bitmap mode, n_{Rf} and n_{Ri} are zero.

To convert the bit rate to be a multiple of 32 kbit/s, the dummy bits for fast data are inserted to the tail of each subframe, and the dummy bits for interleaved data are inserted to the end of the Hyperframe. The number of the dummy bits shall be as follows:

If $t_{Rf} \leq n_{Rmax}$:

$$dummy_{Rf} = 0$$

$$dummy_{Ri} = (f_{Ri} \times 126 + n_{Ri} \times 214) - t_{Ri} \times 340$$

If $t_{Rf} > n_{Rmax}$:

$$dummy_{Rf4} = (f_{Rf} \times 4 + n_{Rf} \times 6) - t_{Rf} \times 10$$

$$dummy_{Rf3} = (f_{Rf} \times 3 + n_{Rf} \times 7) - t_{Rf} \times 10$$

$$dummy_{Ri} = (f_{Ri4} \times 96 + f_{Ri3} \times 30) - t_{Ri} \times 340$$

If the fast data buffer uses single latency only, additional dummy bits are inserted at the tail of each FEXT symbol in the 4 Bitmap- F_R constructed subframe. The number of additional dummy bits inserted at the tail of each FEXT symbol shall be as follows:

$$dummy_{SRf} = f_{Rf3} - f_{Rf4}$$

The receiver shall determine Bitmap- F_R and Bitmap- N_R so that $dummy_{Ri}$ is less than 126, $dummy_{Rf4}$ is less than 4 and $dummy_{Rf3}$ is less than 3 in the initialization sequence. At the receiver, the inserted dummy bits shall be removed.

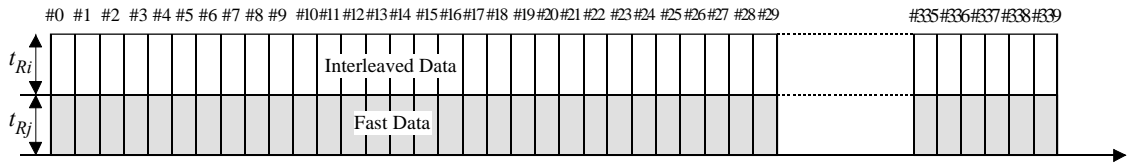

NOTE – Bit Ordering:
The earlier bit is located at the bottom
each symbol in this figure.

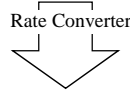

When $t_{Rf} \leq n_{Rmax}$

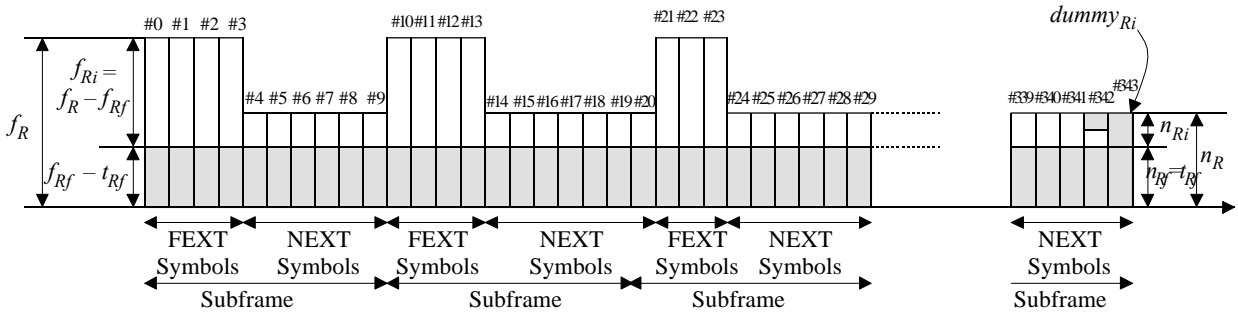

When $t_{Rf} > n_{Rmax}$

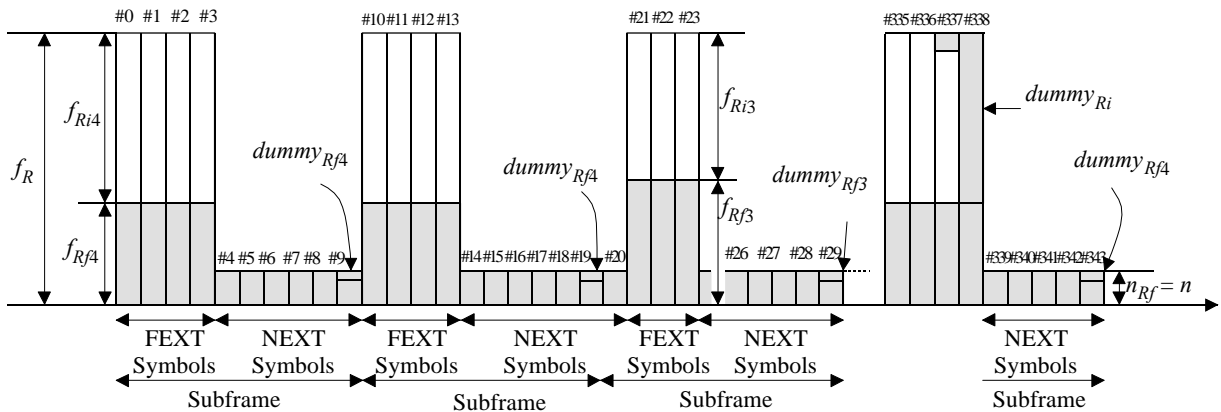

T1532860-99

Figure Q.12/G.992.1 – Bit distribution for Rate Converter under Dual latency and Dual Bitmap mode

Q.4.5 FEXT Bitmapping (replaces 7.16)

The FEXT Bitmapping mode uses the Dual Bitmapping technique (Q.4.4) to transmit data only during FEXT. The ATU-C shall transmit only the pilot tone during the NEXT_R symbol. The ATU-R disables Bitmap-N_C and shall not transmit any signal during the NEXT_C symbol (see Figures Q.10 and Q.15).

Annex Q does not support the FEXT Bitmapping mode.

Q.4.6 Tone Ordering (replacement for 7.7)

A DMT time-domain signal has a high peak-to-average ratio (its amplitude distribution is almost Gaussian), and large values may be clipped by the digital-to-analogue converter. The error signal caused by clipping can be considered as an additive negative impulse for the time sample that was clipped. The clipping error power is almost equally distributed across all tones in the symbol in which clipping occurs. Clipping is therefore most likely to cause errors on those tones

that, in anticipation of a higher received SNR, have been assigned the largest number of bits (and therefore have the densest constellations). These occasional errors can be reliably corrected by the FEC coding if the tones with the largest number of bits have been assigned to the interleave buffer.

The numbers of bits and the relative gains in two bitmaps to be used for every tone are calculated in ATU-R receiver, and sent back to ATU-C according to a defined protocol (see 10.9.14). The pairs of numbers are typically stored, in ascending order of frequency or tone numbers i , in bit and gain tables for Bitmap- F_R and Bitmap- N_R .

For Bitmap- F_R , the "tone-ordered" encoding shall first assign f_{Rf} bits from the rate converter (see Q.4.4.2) to the tones with the smallest number of bits assigned to them, and the remaining f_{Ri} bits to the remaining tones. For Bitmap- N_R , it shall first assign n_{Rf} bits from the rate converter to the tones with the smallest number of bits assigned to them, and the remaining n_{Ri} bits to the remaining tones.

All tones shall be encoded with the number of bits assigned to them; one tone in each bitmap may therefore have a mixture of bits from the fast and interleaved buffers.

The ordered bit tables b'_{iF} and b'_{iN} shall be based on the original bit tables b_{iF} and b_{iN} as follows:

```
For  $k = 0$  to 15 {
    From the bit table, find the set of all  $i$  with the number of bits per tone  $b_i = k$ 
    Assign  $b_i$  to the ordered bit allocation table in ascending order of  $i$ 
}
```

Two ordered bit tables for Bitmap- F_R and Bitmap- N_R shall be prepared. A complementary de-ordering procedure should be performed in ATU-R receiver. It is not necessary, however, to send the results of the ordering process to the receiver because the bit tables F_R and N_R were originally generated in ATU-R, and therefore those tables have all the information necessary to perform the de-ordering.

Q.4.7 Modulation (pertains to 7.11)

Q.4.7.1 Inverse Synchronization Symbol (replaces 7.11.4)

Except for the pilot tone, Inverse Synchronization symbol shall be generated from a tone-by-tone 180 degree phase reversal of Synchronization symbol (i.e. + maps to -, and - maps to +, for each of the 4-QAM signal constellation).

Q.4.7.2 Data subcarriers (modifies 7.11.1.1)

The channel analysis signal defined in 10.6.6 allows for a maximum of NSC-1 carriers (at frequencies nDf , $n = 1$ to NSC-1) to be used.

Q.4.7.3 Nyquist frequency (modifies 7.11.1.3)

The carrier at the Nyquist frequency (#NSC) shall not be used for user data and shall be real valued; other possible uses are for further study.

Q.4.7.4 Modulation by the inverse discrete Fourier transform (replaces 7.11.2)

The modulating transform defines the relationship between the $2 * NSC$ real values x_n and the Z_i :

$$x_n = \sum_{i=0}^{2 * NSC - 1} \exp\left(\frac{j p n i}{NSC}\right) Z_i \quad \text{for } n = 0 \text{ to } 2 * NSC - 1 \quad (7-21)$$

The value of NSC shall be 1024 for this Annex. However, the PSD mask limits the highest used subcarrier index to 869.

The constellation encoder and gain scaling generate only NSC-1 complex values of Z_i . In order to generate real values of x_n , the input values (NSC-1 complex values plus zero at DC and one real value for Nyquist if used) shall be augmented so that the vector Z has Hermitian symmetry. That is,

$$Z_i = \text{conj}(Z'_{2*NSC-i}) \quad \text{for } i = NSC+1 \text{ to } 2*NSC-1 \quad (7-22)$$

Q.4.7.5 Synchronization symbol (modifies 7.11.3)

The synchronization symbol permits recovery of the frame boundary after micro-interruptions that might otherwise force retraining.

The data symbol rate, $f_{\text{ymb}} = 4$ kHz, the carrier separation, $\Delta f = 4.3125$ kHz, and the IDFT size, $N = 2*NSC$, are such that a cyclic prefix of $15.625\%*NSC$ samples could be used. That is, when $NSC = 256$, there are 40 samples in the cyclic prefix.

$$(512 + 40) \times 4.0 = 512 \times 4.3125 = 2208 \quad (7-23)$$

The cyclic prefix shall, however, be shortened to $12.5\%*NSC$ samples, and a synchronization symbol (with a nominal length of $NSC*2.125$ samples) is inserted after every 68 data symbols. That is,

$$(2 + 0.125)*NSC \times 69 = (2 + 0.15625)*NSC \times 68 \quad (7-24)$$

The data pattern used in the synchronization symbol shall be the pseudo-random sequence PRD, (d_n , for $n = 1$ to $2*NSC$) defined by:

$$d_n = 1 \quad \text{for } n = 1 \text{ to } 9 \quad (7-25)$$

$$d_n = d_{n-4} \oplus d_{n-9} \quad \text{for } n = 10 \text{ to } 2*NSC \quad (7-26)$$

The first pair of bits (d_1 and d_2) shall be used for the DC and Nyquist subcarriers (the power assigned to them is zero, so the bits are effectively ignored); the first and second bits of subsequent pairs are then used to define the X_i and Y_i for $i = 1$ to $NSC-1$ as shown in Table 7-13.

The period of the PRD is only 511 bits, so d_{n+511} is equal to d_n . The d_1 - d_9 shall be re-initialized for each synchronization symbol, so each symbol uses the same data.

The two bits that modulate the pilot carrier, shall be overwritten by {0,0}: generating the {+,+} constellation.

The minimum set of subcarriers to be used is the set used for data transmission (i.e. those for which $b_i > 0$); subcarriers for which $b_i = 0$ may be used at a reduced PSD as defined in transmit PSD paragraphs of Annexes A, B and C. The data modulated onto each subcarrier shall be as defined above; it shall not depend on which subcarriers are used.

Q.4.7.6 Cyclic prefix (replaces 7.12)

The last $12.5\%*NSC$ samples of the output of the IDFT (x_n for $n = 2*NSC-0.125*NSC$ to $2*NSC-1$) shall be prepended to the block of $2*NSC$ samples and read out to the digital-to-analogue converter (DAC) in sequence. For example, when $NSC=256$, the subscripts, n , of the DAC samples in sequence are 480 ... 511, 0 ... 511.

The cyclic prefix shall be used for all symbols beginning with the C-RATES1 segment of the initialization sequence, as defined in 10.6.2.

Q.4.8 ATU-C Downstream transmit spectral mask (replaces 7.14)

The downstream spectral mask of Annex Q is as specified in this section. Annex Q does not support overlapped spectrum. Therefore, C-MSG1 bit 16 shall be set to 0, and the PSD mask specified in § Q.4.8.1 shall be used.

Q.4.8.1 Downstream non-overlapped PSD mask definition

The non-overlapped PSD mask is defined with absolute peak values in Figure Q.13. The low frequency stop band is defined for frequencies below 138 kHz (tone 32); the high frequency stop band is defined at frequencies greater than 3750 kHz (tone 869). The in-band region of this PSD mask is the frequency band from 138 kHz to 3750 kHz.

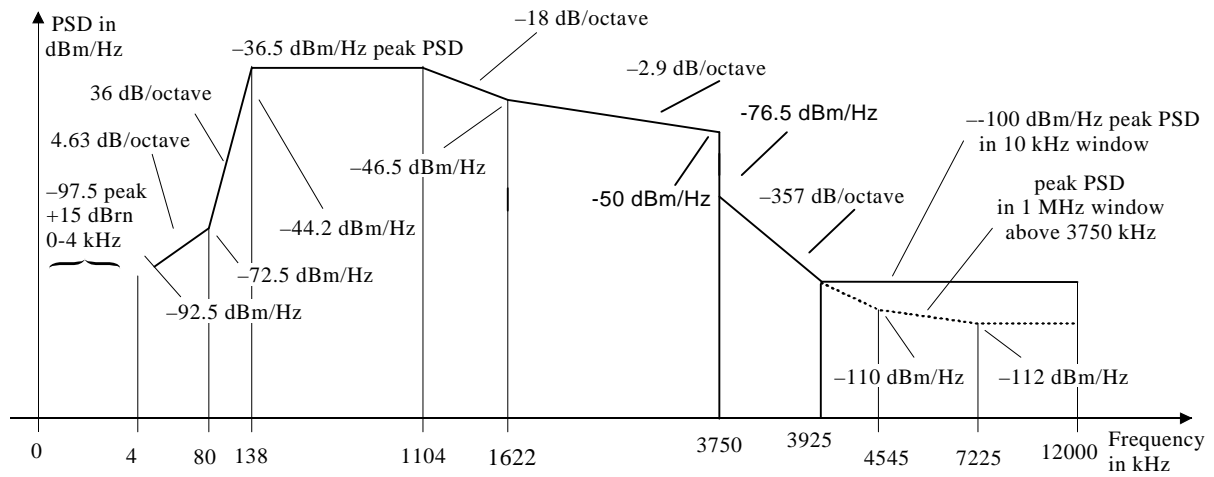

Frequency band f (kHz)	Equation for line (dBm/Hz)
$0 < f < 4$	-97.5
$4 < f < 80$	$-92.5 + 4.63 \cdot \log_2(f/4)$
$80 < f < 138$	$-72.5 + 36 \cdot \log_2(f/80)$
$138 < f < 1104$	-36.5
$1104 < f < 1622$	$-36.5 - 18.0 \cdot \log_2(f/1104)$
$1622 < f < 3750$	$-46.5 - 2.9 \cdot \log_2(f/1622)$
$3750 < f < 3925$	$-76.5 - 357 \cdot \log_2(f/3750)$
$3925 < f < 12000$	-100

Frequency (kHz)	PSD level (dBm/Hz)	Measurement BW
0	-97.5	100 Hz
4	-97.5	100 Hz
4	-92.5	100 Hz
10	interpolated	10 kHz
80	-72.5	10 kHz
138	-44.2	10 kHz
138	-36.5	10 kHz
1104	-36.5	10 kHz
1622	-46.5	10 kHz
3750	-50	10 kHz
3750	-76.5	10 kHz
3925 – 12000	-100	10 kHz

Additionally the PSD mask shall satisfy the following requirements:

Frequency (kHz)	PSD level (dBm/Hz)	Measurement BW
3925	-100	1 MHz
4545	-110	1 MHz
7225	-112	1 MHz
12000	-112	1 MHz

- NOTE 1 – All PSD measurements are in 100 Ω ; the POTS band total power measurement is in 600 Ω .
- NOTE 2 – The breakpoint frequencies and PSD values are exact; the indicated slopes are approximate. The breakpoints in the tables shall be connected by linear straight lines on a dB/log(f) plot.
- NOTE 3 – MBW specifies the Measurement Bandwidth. The MBW specified for a certain breakpoint with frequency f_i is applicable for all frequencies satisfying $f_i < f \leq f_j$, where f_j is the frequency of the next specified breakpoint.
- NOTE 4 – The power in a 1 MHz sliding window is measured in a 1 MHz bandwidth, starting at the measurement frequency i.e. power in the $[f, f + 1 \text{ MHz}]$ window shall conform to the specification at frequency f .

NOTE 5 – The step in the PSD mask at 4 kHz is to protect V.90 performance. Originally, the PSD mask continued the 21 dB/octave slope below 4 kHz hitting a floor of –97.5 dBm/Hz at 3400 Hz. It was recognized that this might impact V.90 performance, and so the floor was extended to 4 kHz.

NOTE 6 – All PSD and power measurements shall be made at the U-C interface.

Figure Q.13: Non-overlapped Downstream Channel PSD Mask

Spectral Shaping of the In-Band Region defined in Q.4.8.2 and Transmit Signals with Limited Transmit Power defined in Q.4.8.3 shall be applied.

Q.4.8.2 Spectral Shaping of the In-Band Region of the PSD Spectrum

In order to shape the ATU-C PSD, frequency dependent gains, called spectral shaping values (ssv_i), shall be applied on each tone during initialization and showtime. The ssv_i values shall be represented with 1 bit before and 10 bits after the decimal point.

Table Q.2 defines the corner points for the nominal PSD shape of the inband region as gain in dB, i.e. log_ssv_i . Log_ssv_i on other tones shall be linearly interpolated between corner points on a logarithmic scale for the gain (dB) and a linear scale for the frequency (Hz). Note that the corner points defined in Table Q.2 are relative values.

The spectral shaping values shall be converted from logarithmic scale (log_ssv_i , dB values) to linear ssv_i values according to:

$$ssv_i = \frac{Round\left(1024 \times 10^{\frac{log_ssv_i}{20}}\right)}{1024}$$

These points are not passed at initialization for the nominal PSD shape but are provided here for reference. However, for additional spectral shaping (see Q.4.8.4), parameters are passed during G.994.1.

The combined accuracy of the process of linear interpolation of the log_ssv_i values and the process of conversion to linear ssv_i values shall be strictly less than one half lsb of the 10 bit after the decimal point format of the linear ssv_i values. No error shall be introduced when log_ssv_i equals 0dB or is interpolated between log_ssv_i values, which equal 0dB.

NOTE 1: The above definition ensures that the maximum deviation between ssv_i values used by transmitter and receiver is one lsb.

NOTE 2: The above needs an accuracy that is strictly < 1/2 lsb. An accuracy of = 1/2 lsb, will lead to inaccurate results.

Table Q.2: Corner points for the non-overlapped nominal in-band PSD shape.

Tone Index	Log_ ssv_i (dB)	Comments
32	0	138 kHz defines the beginning of the inband region. No shaping is applied in the low stop band.
256	0	1104 kHz
376	-10	1622 kHz (-10 = -50 - Nominal_PSD_lowband)
869	-13.5	3750 kHz (-13.5 = -53.5 - Nominal_PSD_lowband)

The absolute values of the transmit PSD are obtained by scaling the relative shaping values with a NOMINAL_PSD_lowband, defined for the lower in-band frequencies. Note that the nominal in-band transmit PSD is frequency dependent. The NOMINAL_PSD_lowband is –40 dBm/Hz (flat from 138 kHz to 1104 kHz) for the non-overlapped spectrum.

NOTE 3: In-band PSD spectral shaping is applied prior to the IFFT.

NOTE 4: The value of MAXNOMATPDs may be limited by regional regulations.

Q.4.8.3 Transmit Signals with Limited Transmit Power

For cases where the transmit signal must be limited to a maximum aggregate total power (e.g. $ATP_{dmax} = +20$ dBm), then

- a) During initialization the PSD transmit level is specified as an offset from the nominal value, i.e. (Nominal_PSD_lowband + ssv_i – x – power cutback) dB, and all values of g_i = 1 for the offset value x and power cutback. The value of x shall be the greater of 0 dB and (21.1 – ATP_{dmax}) dB. For ATP_{dmax} = 20 dBm, the corresponding value of x shall be 1.1 dB.
- b) If b_i>0, then valid range for g_i is [-14.5 to +2.5+x] (dB) ;
 If b_i>0, then g_i shall be in the [g_{sync} – 2.5 to g_{sync} + 2.5] (dB) range;
 If b_i=0, then g_i shall be equal to 0 (linear) or in the [-14.5 to g_{sync}] (dB) range;
 For G.992.1 annex Q, g_{sync} <= x dB

The g_i values shall be constrained by following relation:

Constraint on g _i values	$\sum_{i=6}^{511} ssv_i^2 * g_i^2 \leq \sum_{i=6}^{511} ssv_i^2$
-------------------------------------	--

Q.4.8.4 Additional inband spectral shaping

An ATU-R may request additional downstream inband spectral shaping by passing parameters to the ATU-C in a G.994.1 CLR, MP, or MS message. The ATU-C may select additional downstream inband spectral shaping by passing parameters to the ATU-R in a G.994.1 CL or MS message. Within the framework of G.994.1, the ATU-C has the ability to make the final decision on the downstream inband PSD shape to be used.

The additional inband spectral shaping parameters are listed in Q.7.2.2 and defined in Q.7.3. If the Additional inband spectral shaping Spar(2) bit is set to ONE in Table Q.6.2, its associated Npar(3) octets in Tables Q.6.2.1 to Q.6.2.1.5 define the inband spectral shape. If the additional inband spectral shaping Spar(2) bit is set to ZERO, its associated Npar(3) octets are not transmitted and the nominal inband PSD shape defined in Q.4.8.2 shall be used. These Npar(3) octets define the downstream PSD levels in the low band (between 138 and 1104 kHz), at 1622 kHz and at 3750 kHz. The PSD levels between 1104 kHz and 1622 kHz, and between 1622 kHz and 3750 kHz are linearly interpolated in log scale. The defined values are the PSD level in dB below the NOMINAL_PSD_lowband of –40dbm/Hz. For example, if all three values are set to 20 dB, the result will be a flat PSD of –60dbm/Hz. If the three values are set to 2 dB, 12 dB and 15.5 dB, the result is the PSD defined in Q.4.8.1 reduced by 2dB. In order not to violate the PSD mask defined in Q.4.8.1, the second value shall be no less than 10 dB and the third value shall be no less than 13.5 dB.

Q.4.8.5 Egress control

G.992.1 Annex Q equipment shall be able to reduce the PSD below –80 dBm/Hz for the Amateur radio bands between 1.81 MHz and 2.00 MHz, and between 3.5 MHz and 3.8 MHz. The ATU-C may apply additional spectral shaping as described in Q.4.8.4 to help achieve this requirement.

Q.4.9 Support of higher downstream bit rates with S = 1/2n (replaces 7.6.4)

With a rate of 4000 data frames per second and a maximum of 255 bytes (maximum RS codeword size) per data frame, the ADSL downstream line rate is limited to approximately 8 Mbit/s per latency path. The line rate limit can be

increased beyond this for the interleaved path by mapping $2n$ RS codewords into one FEC data frame (i.e. by using $S = 1/2n$ in the interleaved path). $S = 1/2n$ shall be used in the downstream direction only over bearer channel AS0.

For a selected value of $n \geq 1$, the K_I data bytes per interleaved mux data frame shall be packed into $2n$ RS codewords, split into n equal parts, each consisting of 2 consecutive RS codewords. This forces rate adaptation to occur in 32n kbit/s increments. Each of the n parts of the data frame shall begin with a sync byte and shall obey the rules defined in Table Q.3 for insertion of dummy bytes. The smallest value of n that can support the K_I data bytes shall be used.

Support of $S = 1/2$ (i.e., $n=1$), $S = 1/4$ (i.e., $n=2$), $S = 1/6$ (i.e., $n=3$), and $S = 1/8$ (i.e., $n=4$), is mandatory.

The resulting data frame structure shall be as shown in Figure Q.14.

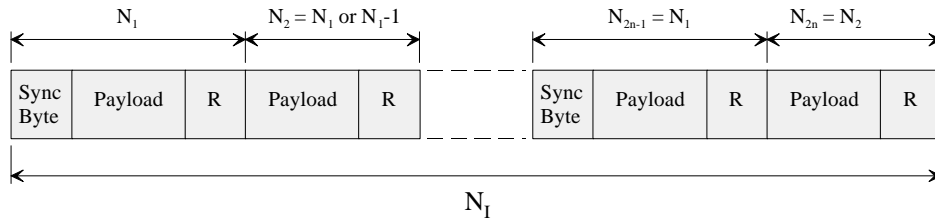

Figure Q.14 – Data frame for $S = 1/2n$ mode

When K_I is divisible by $2n$, the $2n$ codewords have the same length $N_{2i-1} = N_{2i} = (K_I/2n + R_I)$ for $i = 1$ to n , otherwise the odd numbered codewords are equal and are one byte longer than the even numbered codewords, i.e. $N_{2i-1} = (K_I + n)/2n + R_I$ bytes, and $N_{2i} = (K_I - n)/2n + R_I$ bytes for $i = 1$ to n . For the FEC output data frame, $N_I = \sum_{i=1}^n N_i$, with $N_I < 512n - 1$ bytes.

The convolutional interleaver requires all codewords to have the same odd length. To achieve the odd codeword length, insertion of dummy (not transmitted) bytes may be required. For $S = 1/2n$, the dummy byte addition to the odd numbered and/or even numbered codewords at the input of the interleaver shall be as in Table Q.3.

Table Q.3/G.992.1 –Dummy byte insertion at interleaver input for $S = 1/2n$

N_{2i-1}	N_{2i}	Dummy Byte Insertion Action
Odd	Odd	No action
Even	Even	Add one dummy byte at the beginning of all codewords
Odd	Even	Add one dummy byte at the beginning of each even numbered codeword
Even	Odd	Add one dummy byte at the beginning of each odd numbered codeword and two dummy bytes at the beginning of each even numbered codeword [the de-interleaver shall insert one dummy byte into the de-interleaver matrix on the first byte and the $(D + 1)$ th byte of the corresponding codeword to make the addressing work properly]

Q.5 ATU-R Functional Characteristics (pertains to clause 8)

Q.5.1 Framing (pertains to 8.4)

Q.5.1.1 Superframe structure (replaces 8.4.1.1)

The superframe structure of ATU-R transmitter is identical to that of ATU-C transmitter, as specified in Q.4.3.1.

Q.5.1.2 Hyperframe structure (replaces 8.4.1.3)

The hyperframe structure of ATU-R transmitter is functionally similar to that of ATU-C transmitter, except that the

inverse synch symbol is used in the 1st superframe (SPF#0) (see Figure Q.15). The hyperframe is composed of 345 DMT symbols, numbered from 0 to 344. Each symbol is under FEXT_C or NEXT_C duration (see Q.5.3), and the following numerical formula gives the information which duration N_{dm_t}-th DMT symbol belongs to at ATU-R transmitter (see Figure Q.16).

For N_{dm_t} = 0, 1, ..., 344

$$S = 272 \times N_{dm_t} \bmod 2760$$

if { (S > a) and (S + 271 < a + b) } then FEXT_C symbol
 else then NEXT_C symbol

where a = 1315, b = 1293

128 DMT symbols are allocated in the FEXT_C duration, and 217 DMT symbols are allocated in the NEXT_C duration. The symbols are composed of:

FEXT_C symbol:

Number of symbol using Bitmap-F_C = 126
 Number of synch symbol = 1
 Number of inverse synch symbol = 1

NEXT_C symbol:

Number of symbol using Bitmap-N_C = 214
 Number of synch symbol = 3

During FEXT Bitmapping mode, the ATU-R shall not transmit any signal.

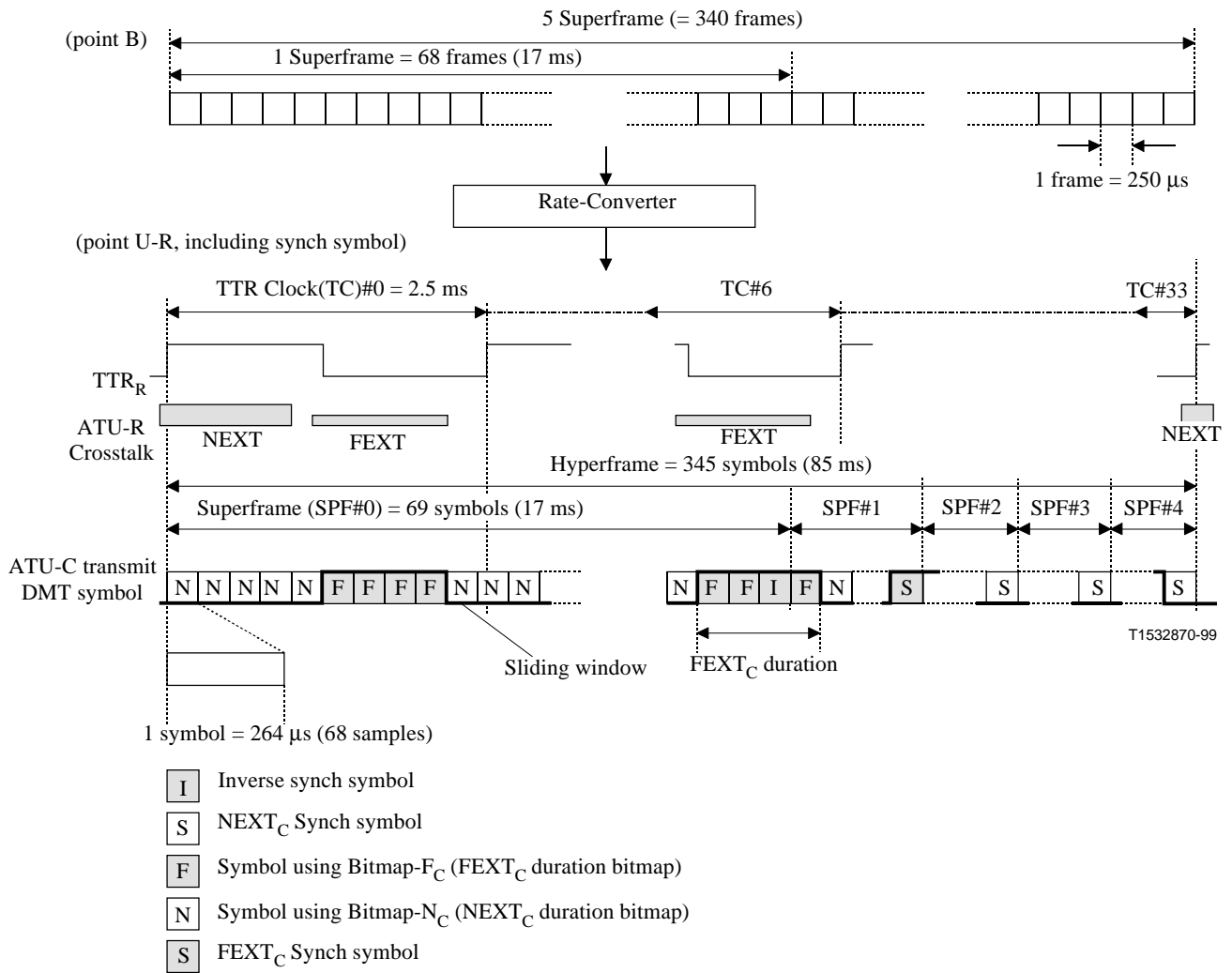

Figure Q.15/G.992.1 – Hyperframe structure for upstream

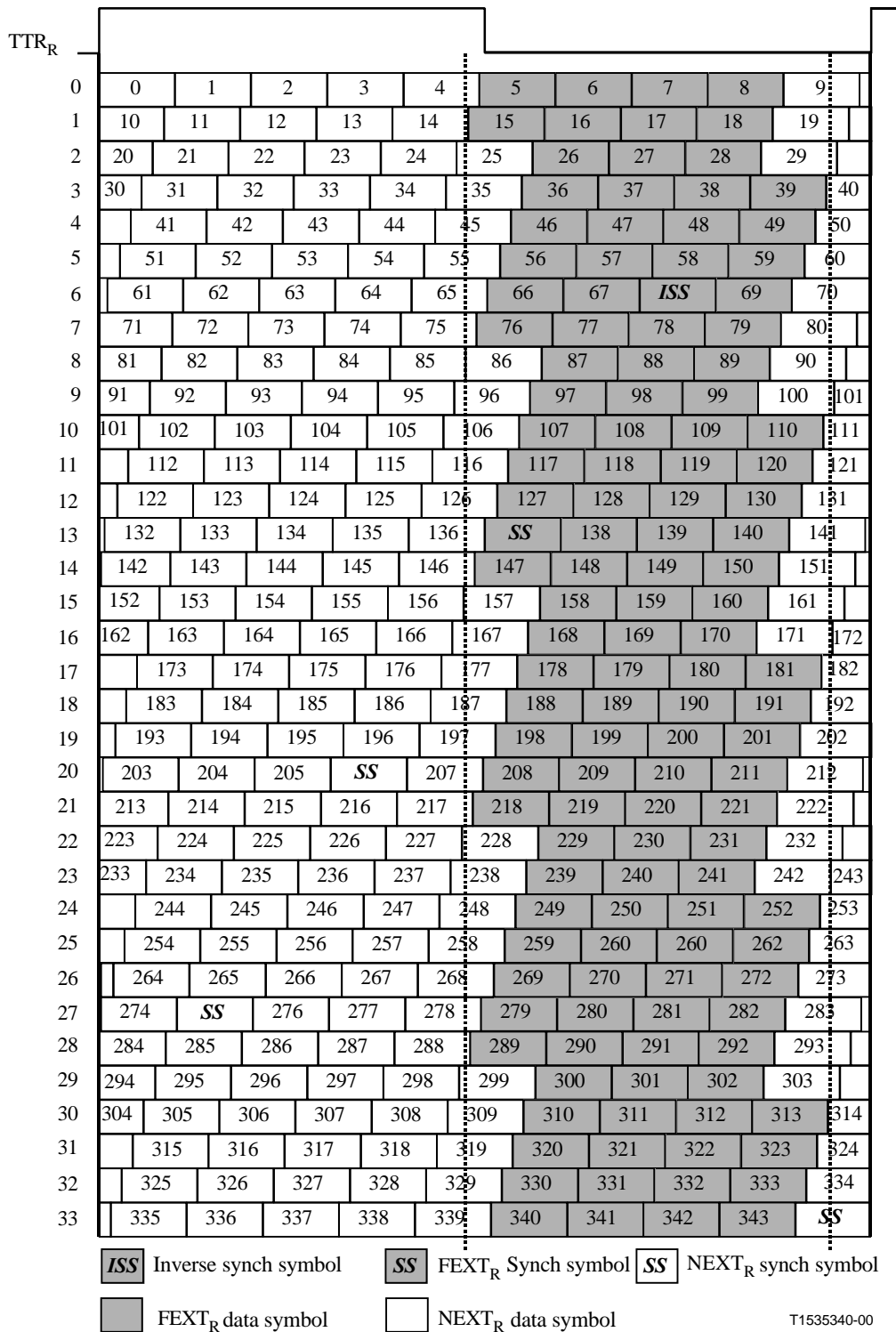

Figure Q.16/G.992.1 – Symbol pattern in a hyperframe with cyclic prefix – Upstream

Q.5.1.3 Subframe structure (replaces 8.4.1.4)

A subframe is 10 consecutive DMT symbols (except for sync symbols) as shown in Table Q.4. The 34 subframes form a hyperframe.

Table Q.4/G.992.1 – Subframe (upstream)

Subframe No.	DMT symbol No.	Note
0	0-9	
1	10-19	
2	20-29	
3	30-39	
4	40-49	
5	50-59	
6	60-70	#68 is Inverse Synch Symbol
7	71-80	
8	81-90	
9	91-100	
10	101-110	
11	111-120	
12	121-130	
13	131-141	#137 is Synch Symbol
14	142-151	
15	152-161	
16	162-171	
17	172-181	
18	182-191	
19	192-201	
20	202-212	#206 is Synch Symbol
21	213-222	
22	223-232	
23	233-242	
24	243-252	
25	253-262	
26	263-272	
27	273-283	#275 is Synch Symbol
28	284-293	
29	294-303	
30	304-313	
31	314-323	
32	324-333	
33	334-344	#344 is Synch Symbol

Q.5.2 Dual Bitmapping and rate conversion (replaces 8.15)

The function of the rate converter (see Q.5.2.2), tone ordering (see Q.5.4), constellation encoding, and gain scaling shall use one of two bitmaps stored in the ATU. This method is called the dual bitmap.

Q.5.2.1 Dual Bitmap (new)

The Dual Bitmap switching shall be the same as for the downstream data, specified in Q.4.4.1. The number of bits and the relative gains to be used for every tone are calculated in the bit loading algorithm during the initialization sequence, and transmitted in C-B&G.

Q.5.2.2 Rate Converter (new)

The rate converter buffering changes the data frame boundaries between the reference points B and C according to Bitmap- F_C , Bitmap- N_C and the Sliding Window. Two independent rate converters are prepared for fast data and interleaved data. The amounts of fast and interleaved data in Bitmap- F_C and Bitmap- N_C shall be calculated in the following formulae:

If $t_{Cf} \leq n_{Cmax}$:

$$\begin{aligned}
n_{Cf} &= t_{Cf} \\
n_{Ci} &= n_C - n_{Cf} \\
f_{Cf} &= t_{Cf} \\
f_{Ci} &= f_C - f_{Cf}
\end{aligned}$$

If $t_{Cf} > n_{Cmax}$:

$$\begin{aligned}
n_{Cf} &= n_{Cmax} \\
n_{Ci} &= 0 \\
f_{Cf} &= \begin{cases} f_{Cf4} = \left\lfloor \frac{t_{Cf} \times 10 - n_{Cf} \times 6}{4} \right\rfloor \\ f_{Cf3} = \left\lfloor \frac{t_{Cf} \times 10 - n_{Cf} \times 7}{3} \right\rfloor \end{cases} \\
f_{Ci} &= \begin{cases} f_{Ci4} = f_C - f_{Cf4} \\ f_{Ci3} = f_C - f_{Cf3} \end{cases}
\end{aligned}$$

Where:

- t_{Cf} is the number of allocated bits in one frame for fast bytes at the reference point B.
- t_{Ci} is the number of allocated bits for interleaved bytes at the reference point B.
- f_{Cf} and n_{Cf} are the numbers of fast bits in Bitmap- F_C and Bitmap- N_C , respectively.
- f_{Cf3} is the number of fast bits in Bitmap- F_C if the subframe (see Q.5.1.3) contains 3 Bitmap- F_C except for synch symbols.
- f_{Cf4} is the number of fast bits in Bitmap- F_C if the subframe contains 4 Bitmap- F_C except for synch symbols.
- f_{Ci} and n_{Ci} are the numbers of interleaved bits in Bitmap- F_C and Bitmap- N_C , respectively.
- n_C is the number of total bits in Bitmap- N_C , which is specified in the B&G tables.

During FEXT Bitmap mode, n_{Cf} and n_{Ci} are zero.

To convert the bit rate to be a multiple of 32 kbit/s, the dummy bits for fast data are inserted to the tail of each subframe, and the dummy bits for interleaved data are inserted to the end of the Hyperframe. The number of the dummy bits shall be as follows:

If $t_{Cf} \leq n_{Cmax}$:

$$\begin{aligned}
dummy_{Cf} &= 0 \\
dummy_{Ci} &= (f_{Ci} \times 126 + n_{Ci} \times 214) - t_{Ci} \times 340
\end{aligned}$$

If $t_{Cf} > n_{Cmax}$:

$$\begin{aligned}
dummy_{Cf4} &= (f_{Cf} \times 4 + n_{Cf} \times 6) - t_{Cf} \times 10 \\
dummy_{Cf3} &= (f_{Cf} \times 3 + n_{Cf} \times 7) - t_{Cf} \times 10 \\
dummy_{Ci} &= (f_{Ci4} \times 96 + f_{Ci3} \times 30) - t_{Ci} \times 340
\end{aligned}$$

If the fast data buffer uses single latency only, additional dummy bits are inserted at the tail of each FEXT symbol in the 4 Bitmap- F_C constructed subframe. The number of additional dummy bits inserted at the tail of each FEXT symbol shall be as follows:

$$dummy_{SCf} = f_{Cf3} - f_{Cf4}$$

The receiver shall determine Bitmap-FC and Bitmap-NC so that $dummy_{C_i}$ is less than 126, $dummy_{C_f4}$ is less than 4 and $dummy_{C_f3}$ is less than 3 in the initialization sequence. At the receiver, the inserted dummy bits shall be removed.

Q.5.3 FEXT Bitmapping (replaces 8.16)

The FEXT Bitmapping mode uses the Dual Bitmapping technique (Q.4.4) to transmit data only during FEXT. The ATU-C shall transmit only the pilot tone during the NEXT_R symbol. The ATU-R disables Bitmap-NC and shall not transmit any signal during the NEXT_C symbol (see Figures Q.10 and Q.15).

Annex Q does not support the FEXT Bitmapping mode.

Q.5.4 Tone Ordering (pertains to 8.7)

The tone ordering algorithm shall be the same as for the downstream data, specified in Q.4.4.

For Bitmap-FC, the "tone-ordered" encoding shall first assign f_{C_f} bits from the rate converter (see Q.5.2.2) to the tones with the smallest number of bits assigned to them, and the remaining f_{C_i} bits to the remaining tones. For Bitmap-NC, it shall first assign n_{C_f} bits from the rate converter to the tones with the smallest number of bits assigned to them, and the remaining n_{C_i} bits to the remaining tones. Two ordered bit tables for Bitmap-FC and Bitmap-NC shall be prepared.

Q.5.5 Modulation (pertains to 8.11)

Q.5.5.1 Inverse synchronization symbol (replaces 8.11.4)

Inverse Synchronization symbol shall be generated from a tone-by-tone 180 degree phase reversal of Synchronization symbol (i.e. + maps to -, and - maps to +, for each of the 4-QAM signal constellation).

Q.5.5.2 Gain scaling in synchronization symbol (new)

At initialization time, the sync symbol reference transmit PSD level shall be set at the nominal PSD level $+10\log(g_{\text{sync}}^2)$ dBm/Hz, with g_{sync}^2 defined as the average g_i^2 value over the used (i.e. $b_i > 0$) subcarriers in the NEXT or FEXT bitmap, whichever results in the highest average gain. The sync symbol reference transmit PSD shall not be updated with used subcarrier gain changes during SHOWTIME.

Q.5.6 ATU-R Upstream Transmit Spectral Mask (supplements 8.14)

The upstream spectral mask of Annex Q uses the same mask as Annex A.

Q.6 EOC Operation and Maintenance (pertains to clause 9)

Q.6.1 ADSL line related primitives (supplements 9.3.1)

Q.6.1.1 ADSL line related near-end defects (supplements 9.3.1.3)

Two near-end defects are further defined:

- *Loss-of-signal (LOS)*: The ADSL power shall be measured only in the FEXT_C duration at ATU-C, or only in the FEXT_R duration at ATU-R.
- *Severely errored frame (SEF)*: A SEF defect occurs when the content of two consecutively received ADSL synchronization symbols in the FEXT_C duration at ATU-C, or in the FEXT_R duration at ATU-R, does not correlate with the expected content over a subset of the tones. An SEF defect terminates when the content of two consecutively received ADSL synchronization symbols in the FEXT_C duration at ATU-C, or in the FEXT_R duration at ATU-R, correlate with the expected contents over the same subset. The correlation method, the selected subset of tones, and the threshold for declaring these defect conditions are implementation discretionary.

Q.6.1.2 ADSL line related far-end defects (supplements 9.3.1.4)

Loss-of-signal is further defined:

- *Loss-of-signal (LOS)*: The ADSL power shall be measured only in the FEXT_C duration at ATU-C, or only in the FEXT_R duration at ATU-R.

Q.6.2 Test Parameters (supplements 9.5)

Q.6.2.1 Near-end test parameters (supplements 9.5.1)

The near-end primitives are further defined:

- *Attenuation (ATN)*: The received signal power shall be measured only in the FEXT_C duration at ATU-C, or only in the FEXT_R duration at ATU-R.
- *Signal-to-Noise ratio (SNR) margin*: During FEXT Bitmap mode, this primitive represents the snr margin in the FEXT_C duration at ATU-C, or in the FEXT_R duration at ATU-R.

Q.6.2.2 Far-end test parameters (supplements 9.5.2)

The far-end primitives are further defined:

- *Attenuation (ATN)*: The received signal power shall be measured only in the FEXT_C duration at ATU-C, or only in the FEXT_R duration at ATU-R.
- *Signal-to-Noise ratio SNR margin*: During FEXT Bitmap mode, this primitive represents the snr margin in the FEXT_C duration at ATU-C, or in the FEXT_R duration at ATU-R.

Q.6.3 Data registers in the ATU-R (supplements 9.2.4)

For the $S=1/2n$ framing mode (see §Q.4.9), the downstream RS_1 shall be the number of parity bytes per sync byte, i.e., $RS_1 = R_1/(n*S)$.

Q.7 Initialization (pertains to clause 10)

Q.7.1 Initialization with Hyperframe (replaces 10.1.5)

The exchange of messages between ATU-C and ATU-R should be performed in FEXT_C and FEXT_R. The DMT symbol has two symbol rates: one is 4.3125 kbaud for the symbol without a cyclic prefix, and the other is $4 \times 69/68$ kbaud for the symbol with a cyclic prefix. 32 times of the TTR has the same period as 345 times of the 4.3125 kbaud, and 34 times of the TTR is the same as 345 times of $4 \times 69/68$ kHz.

During FEXT Bitmap mode, the ATU-R shall not transmit any signal during the NEXT_C symbols duration and the ATU-C shall transmit only the pilot tone as the NEXT_R signal except:

- C-PILOT1 (C-PILOT1A) which is accompanied by a signal to allow the ATU-C to indicate the phase of TTR_C to the ATU-R (see Q.7.4.1);
- C-QUIETn where no signal is transmitted.

The ATU-C begins transmitting C-PILOT1 at the beginning of the hyperframe without cyclic prefix. The ATU-C informs the phase of the TTR_C to ATU-R during C-PILOT1. The ATU-R begins transmitting R-REVERB1 at the beginning of the hyperframe without cyclic prefix. The ATU-R performs the training of any receiver equalizer using this phase information of the TTR_R generated from received TTR_C.

From C-PILOT1 to C-SEGUE1, the following numerical formula gives the information which duration N_{dmT} -th DMT symbol belongs to at ATU-R (see Figure Q.17).

For $N_{\text{dmt}} = 0, 1, \dots, 344$
 $S = 256 \times N_{\text{dmt}} \bmod 2760$
if $\{ (S + 255 < a) \text{ or } (S > a + b) \}$ then FEXT_R symbols
else then NEXT_R symbols
where $a = 1243, b = 1461$

In order to enter C-RATES1 at the beginning of the hyperframe with cyclic prefix, the number of symbols from C-PILOT1 to C-SEGUE1 shall be a multiple of 345 DMT symbols.

From R-REVERB1 to R-SEGUE1, the following numerical formula gives the information which duration N_{dmt} -th symbol belongs to at ATU-C (see Figure Q.18).

For $N_{\text{dmt}} = 0, 1, \dots, 344$,
 $S = 256 \times N_{\text{dmt}} \bmod 2760$
if $\{ (S > a) \text{ and } (S + 255 < a + b) \}$ then FEXT_C symbols
else then NEXT_C symbols
where $a = 1315, b = 1293$

From C-RATES1 to C-SEGUE3, the number of symbols is a multiple of 345 DMT symbols. The following numerical formula gives the information which duration N_{dmt} -th DMT symbol belongs to. ATU-C transmits the message data in FEXT_R symbols (see Figure Q.11).

For $N_{\text{dmt}} = 0, 1, \dots, 344$
 $S = 272 \times N_{\text{dmt}} \bmod 2760$
if $\{ (S + 271 \geq a) \text{ and } (S \leq a + b) \}$ then NEXT_R symbols
else then FEXT_R symbols
where $a = 1243, b = 1461$

The ATU-R enters R-REVERB3 at the beginning of the hyperframe with cyclic prefix, which is extracted from received signal. From R-REVERB3 to R-SEGUE5, the number of symbols is a multiple of 345 DMT symbols. The following numerical formula gives the information which duration N_{dmt} -th DMT symbol belongs to. ATU-R transmits the message data in FEXT_C symbols (see Figure Q.16).

For $N_{\text{dmt}} = 0, 1, \dots, 344$
 $S = 272 \times N_{\text{dmt}} \bmod 2760$
if $\{ (S > a) \text{ and } (S + 271 < a + b) \}$ then FEXT_C symbols
else then NEXT_C symbols
where $a = 1315, b = 1293$

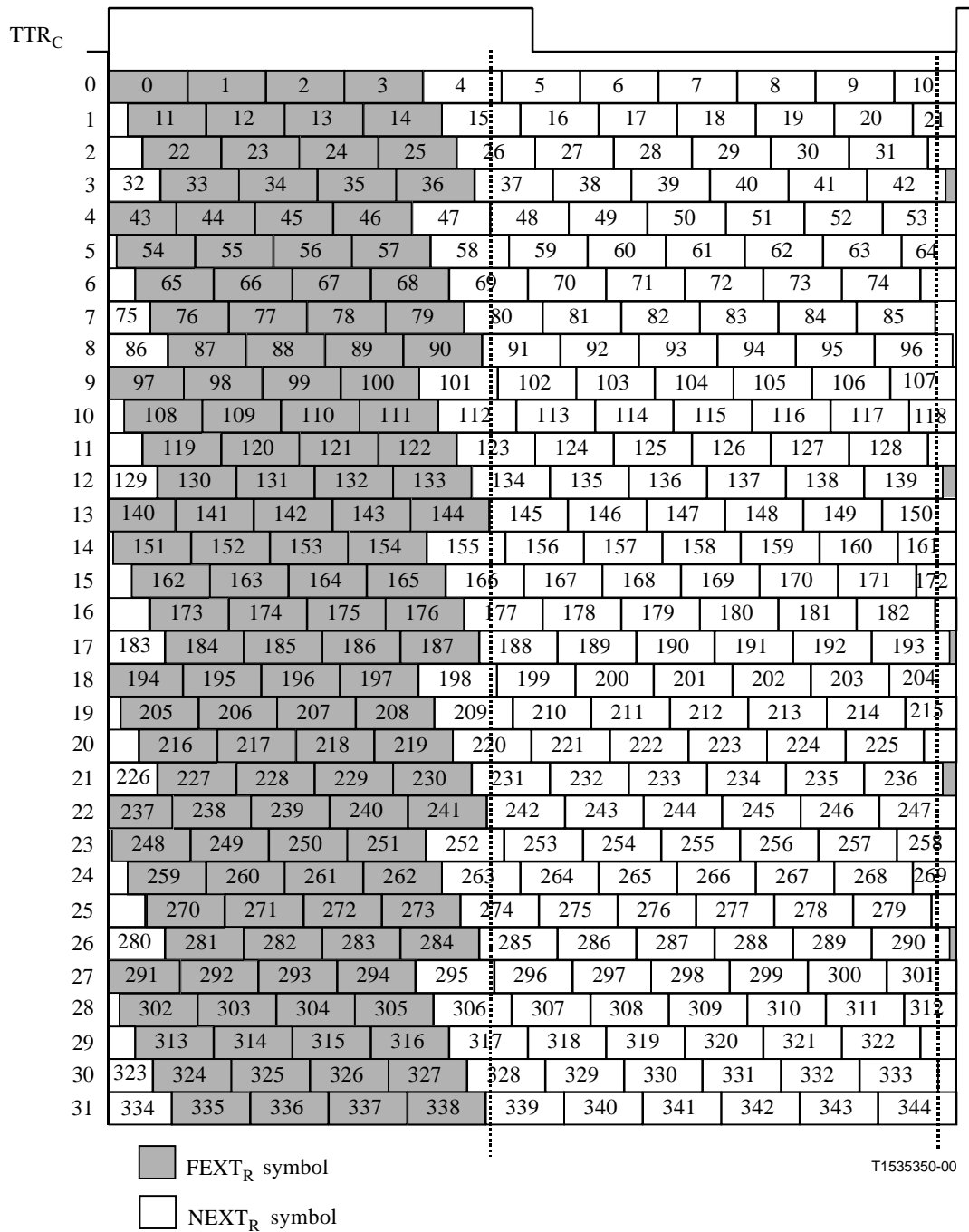

Figure Q.17/G.992.1 – Symbol pattern in a hyperframe without cyclic prefix – Downstream

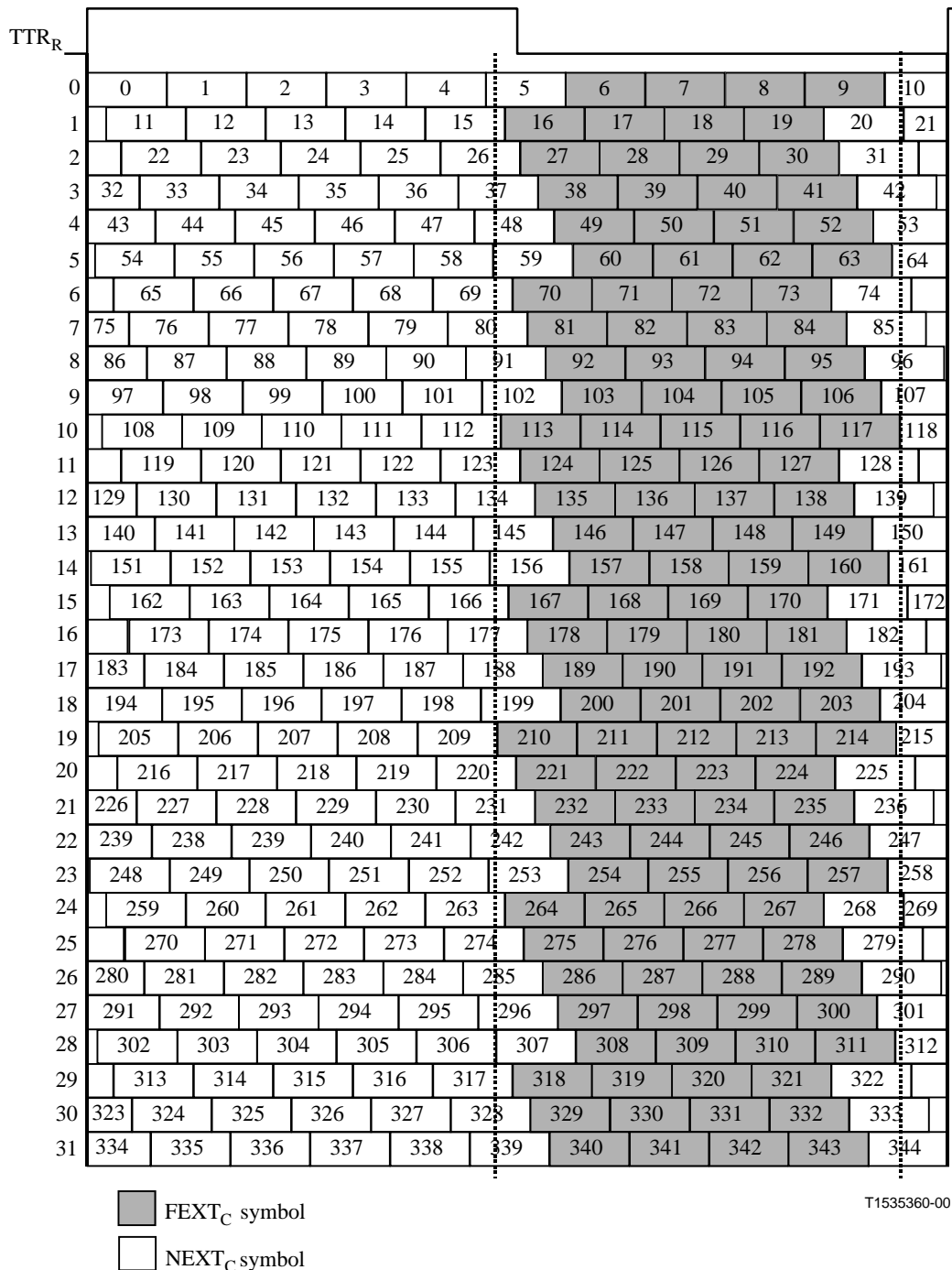

Figure Q.18/G.992.1 – Symbol pattern in a hyperframe without cyclic prefix – Upstream

Q.7.2 Handshake – Non-standard information block (new)

This section defines the format of the G.994.1 non-standard information block to support Annex Q, and tabulates the parameters used by Annex Q. The use of these parameters is described in §Q.7.3 and §Q.7.4.

Q.7.2.1 Non-standard information block format (new)

Figure Q.19 defines the format of the non-standard information block.

8	7	6	5	4	3	2	1	
Non-standard information length = M + 6 (1 octet)								
T.35 country code (2 octets – see Note 1)								
Provider code (vendor identification) (4 octets – see Note 2)								
Vendor-specific information (M octets – Note 3)								

NOTE 1 – The value of this field shall be B5 00, the country code for USA

NOTE 2 – The value of this field shall be 43 45 4E 54, ASCII “CENT” for Centillum Communications

NOTE 3 – These octets are defined in §Q.7.2.2. Formatting of these octets shall comply with the parsing rules defined in G.994.1 §9.2.1 to §9.2.3

Figure Q.19 – Non-standard information block format

Q.7.2.2 Non-standard information block parameters (new)

The G.994.1 non-standard parameters for Annex Q are listed in Tables Q.5 to Q.6.2.1.2.5 below.

Table Q.5 – Non-standard information field – NPar(1) coding

Bits								NPar(1)s
8	7	6	5	4	3	2	1	
x	x	x	x	x	x	x	1	Reserved for future use
x	x	x	x	x	x	1	x	Reserved for future use
x	x	x	x	x	1	x	x	Reserved for future use
x	x	x	x	1	x	x	x	Reserved for future use
x	x	x	1	x	x	x	x	Reserved for future use
x	x	1	x	x	x	x	x	Reserved for future use
x	1	x	x	x	x	x	x	Reserved for future use
x	0	0	0	0	0	0	0	No parameters in this octet

Table Q.6 – Non-standard information field – SPar(1) coding

Bits								SPar(1)s
8	7	6	5	4	3	2	1	
x	x	x	x	x	x	x	1	G.992.1 Annex Q
x	x	x	x	x	x	1	x	Reserved for future use
x	x	x	x	x	1	x	x	Reserved for future use
x	x	x	x	1	x	x	x	Reserved for future use
x	x	x	1	x	x	x	x	Reserved for future use
x	x	1	x	x	x	x	x	Reserved for future use
x	1	x	x	x	x	x	x	Reserved for future use
x	0	0	0	0	0	0	0	No parameters in this octet

Table Q.6.1 – Non-standard information field – G.992.1 Annex Q NPar(2) coding

Bits								G.992.1 Annex Q NPar(2)s	
8	7	6	5	4	3	2	1		
x	x	x	x	x	x	x	1	$n_{C-PILOT1} = 64$	
x	x	x	x	x	x	1	x	$n_{C-PILOT1} = 128$	
x	x	x	x	x	1	x	x	$n_{C-PILOT1} = 256$	
x	x	x	x	1	x	x	x	Amateur radio notch – 1.8 MHz band	
x	x	x	1	x	x	x	x	Amateur radio notch – 3.5 MHz band	
x	x	1	x	x	x	x	x	Reserved for future use	
x	x	0	0	0	0	0	0	No parameters in this octet	

Table Q.6.2 – Non-standard information field – G.992.1 Annex Q SPar(2) coding

Bits								G.992.1 Annex Q SPar(2)s	
8	7	6	5	4	3	2	1		
x	x	x	x	x	x	x	1	Additional inband spectral shaping	
x	x	x	x	x	x	1	x	Reserved for future use	
x	x	x	x	x	1	x	x	Reserved for future use	
x	x	x	x	1	x	x	x	Reserved for future use	
x	x	x	1	x	x	x	x	Reserved for future use	
x	x	1	x	x	x	x	x	Reserved for future use	
x	x	0	0	0	0	0	0	No parameters in this octet	

Table Q.6.2.1 – Non-standard information field – G.992.1 Annex Q Npar(3) coding Octet 1

Bits								G.992.1 Annex Q Npar(3)s Octet 1	
8	7	6	5	4	3	2	1		
x	x					x	x	NOMINAL_PSD_lowband (bits 8 & 7)	
x	x	x	x	x	x	Reserved for future use			

Table Q.6.2.1.1 – Non-standard information field – G.992.1 Annex Q Npar(3) coding Octet 2

Bits								G.992.1 Annex Q Npar(3)s Octet 2	
8	7	6	5	4	3	2	1		
x	x	x	x	x	x	x	x	NOMINAL_PSD_lowband (bits 6 to 1)	

Table Q.6.2.1.2 – Non-standard information field – G.992.1 Annex Q Npar(3) coding Octet 3

Bits		6	5	4	3	2	1	
8	7							G.992.1 Annex Q Npar(3)s Octet 3
x	x					x	x	PSD level at 1622 kHz (bits 8 & 7)
x	x	x	x	x	x			Reserved for future use

Table Q.6.2.1.3 – Non-standard information field – G.992.1 Annex Q Npar(3) coding Octet 4

Bits		6	5	4	3	2	1	
8	7							G.992.1 Annex Q Npar(3)s Octet 4
x	x	x	x	x	x	x	x	PSD level at 1622 kHz (bits 6 to 1)

Table Q.6.2.1.4 – Non-standard information field – G.992.1 Annex Q Npar(3) coding Octet 5

Bits		6	5	4	3	2	1	
8	7							G.992.1 Annex Q Npar(3)s Octet 5
x	x					x	x	PSD level at 3750 kHz (bits 8 & 7)
x	x	x	x	x	x			Reserved for future use

Table Q.6.2.1.5 – Non-standard information field – G.992.1 Annex Q Npar(3) coding Octet 6

Bits		6	5	4	3	2	1	
8	7							G.992.1 Annex Q Npar(3)s Octet 6
x	x	x	x	x	x	x	x	PSD level at 3750 kHz (bits 6 to 1)

Q.7.3 Handshake – Parameter definitions (supplements 10.2)

Q.7.3.1 Handshake – ATU-C (supplements 10.2)

Q.7.3.1.1 CL messages (supplements 10.2.1)

See Table Q.7.

Table Q.7/G.992.1 – ATU-C CL message NPar(2) bit definitions for Annex Q

NSF parameter	Definition

G.992.1 Annex Q	If set to ONE, this Spar(1) bit indicates that the ATU-C is configured to support G.992.1 Annex Q.
n _C -PILOT ₁ =64	This Npar(2) bit shall be set to ONE, indicating that the ATU-C supports transmission of pilot tone on subcarrier 64.
n _C -PILOT ₁ =128	This Npar(2) bit shall be set to ONE, indicating that the ATU-C supports transmission of pilot tone on subcarrier 128.
n _C -PILOT ₁ =256	This Npar(2) bit shall be set to ONE, indicating that the ATU-C supports transmission of pilot tone on subcarrier 256.
Amateur radio notch – 1.8 MHz band	If set to ONE, this Npar(2) bit indicates that the ATU-C is configured to reduce its transmit power between 1.81 and 2.0 MHz to –80 dBm.
Amateur radio notch – 3.5 MHz band	If set to ONE, this Npar(2) bit indicates that the ATU-C is configured to reduce its transmit power between 3.5 and 3.8 MHz to –80 dBm.
Additional inband spectral shaping	If set to ONE, this Spar(2) bit indicates that the ATU-C is configured to apply additional downstream inband spectral shaping as defined by the values of REDUCED_PSD_lowband, PSD level at 1622 kHz, and PSD level at 3750 kHz
REDUCED_PSD_lowband	This 8 bit Npar(3) parameter indicates the relative downstream PSD level that the ATU-C is configured to use in the passband below 1104 kHz. It is coded in steps of 0.125dB relative to NOMINAL_PSD_lowband (–40dBm/Hz). For example, 00000000 means –40 dBm/Hz; 00001101 means -41.625 dBm/Hz.
PSD level at 1622 kHz	This 8 bit Npar(3) parameter indicates the relative downstream PSD level that the ATU-C is configured to use at 1622 kHz. It is coded in steps of 0.125dB relative to NOMINAL_PSD_lowband (–40dBm/Hz). For example, 00000000 means –40 dBm/Hz; 00001101 means -41.625 dBm/Hz. The PSD level shall be linearly interpolated in dBs between the REDUCED_PSD_lowband level at 1104 kHz and the PSD level at 1622 kHz.
PSD level at 3750 kHz	This 8 bit Npar(3) parameter indicates the relative downstream PSD level that the ATU-C is configured to use at 3750 kHz. It is coded in steps of 0.125dB relative to NOMINAL_PSD_lowband (–40dBm/Hz). For example, 00000000 means –40 dBm/Hz; 00001101 means -41.625 dBm/Hz. The PSD level shall be linearly interpolated in dBs between the PSD level at 1622 kHz and the PSD level at 3750 kHz.

Q.7.3.1.2 MS messages (supplements 10.2.2)

See Table Q.8.

Table Q.8/G.992.1 – ATU-C MS message NPar(2) bit definitions for Annex Q

NSF bit	Definition
G.992.1 Annex Q	If set to ONE, this Spar(1) bit indicates that the ATU-C is selecting G.992.1 Annex Q.
n _C -PILOT ₁ =64	If set to ONE, this Npar(2) bit shall indicate that the ATU-C is selecting the pilot tone on subcarrier 64 (Note 1).
n _C -PILOT ₁ =128	If set to ONE, this Npar(2) bit shall indicate that the ATU-C is selecting the pilot tone on subcarrier 128 (Note 1).
n _C -PILOT ₁ =256	If set to ONE, this Npar(2) bit shall indicate that the ATU-C is selecting the pilot tone on subcarrier 256 (Note 1).
Amateur radio notch – 1.8 MHz band	If set to ONE, this Npar(2) bit indicates that the ATU-C shall reduce its transmit power between 1.81 and 2.0 MHz to –80 dBm.
Amateur radio notch – 3.5 MHz band	If set to ONE, this Npar(2) bit indicates that the ATU-C shall reduce its transmit power between 3.5 and 3.8 MHz to –80 dBm.

Additional inband spectral shaping	If set to ONE, this Spar(2) bit indicates that the ATU-C shall apply additional downstream inband spectral shaping as defined by the values of REDUCED_PSD_lowband, PSD level at 1622 kHz, and PSD level at 3750 kHz
REDUCED_PSD_lowband	This 8 bit Npar(3) parameter indicates the relative downstream PSD level that the ATU-C shall apply in the passband below 1104 kHz. It is coded in steps of 0.125dB relative to NOMINAL_PSD_lowband (-40dBm/Hz). For example, 00000000 means -40 dBm/Hz; 00001101 means -41.625 dBm/Hz.
PSD level at 1622 kHz	This 8 bit Npar(3) parameter indicates the relative downstream PSD level that the ATU-C shall apply at 1622 kHz. It is coded in steps of 0.125dB relative to NOMINAL_PSD_lowband (-40dBm/Hz). For example, 00000000 means -40 dBm/Hz; 00001101 means -41.625 dBm/Hz. The PSD level shall be linearly interpolated in dBs between the REDUCED_PSD_lowband level at 1104 kHz and the PSD level at 1622 kHz.
PSD level at 3750 kHz	This 8 bit Npar(3) parameter indicates the relative downstream PSD level that the ATU-C shall apply at 3750 kHz. It is coded in steps of 0.125dB relative to NOMINAL_PSD_lowband (-40dBm/Hz). For example, 00000000 means -40 dBm/Hz; 00001101 means -41.625 dBm/Hz. The PSD level shall be linearly interpolated in dBs between the PSD level at 1622 kHz and the PSD level at 3750 kHz.
Note 1: One and only one pilot tone bit shall be set in an MS message.	

Q.7.3.2 Handshake – ATU-R (supplements 10.3)

Q.7.3.2.1 CLR messages (supplements 10.3.1)

See Table Q.9.

Table Q.9/G.992.1 – ATU-R CLR message NPar(2) bit definitions for Annex Q

NSF bit	Definition
G.992.1 Annex Q	If set to ONE, this Spar(1) bit indicates that the ATU-R is configured to support G.992.1 Annex Q.
n _{C-PILOT1} =64	This Npar(2) bit shall be set to ONE, indicating that the ATU-R supports reception of pilot tone on subcarrier 64.
n _{C-PILOT1} =128	This Npar(2) bit shall be set to ONE, indicating that the ATU-R supports reception of pilot tone on subcarrier 128.
n _{C-PILOT1} =256	This Npar(2) bit shall be set to ONE, indicating that the ATU-R supports reception of pilot tone on subcarrier 256.
Amateur radio notch – 1.8 MHz band	This Npar(2) bit shall be set to ONE, indicating that the ATU-R supports the 1.8 MHz Amateur radio band notch.
Amateur radio notch – 3.5 MHz band	This Npar(2) bit shall be set to ONE, indicating that the ATU-R supports the 3.5 MHz Amateur radio band notch.
Additional inband spectral shaping	If set to ONE, this Spar(2) bit indicates that the ATU-R wishes to have additional downstream inband spectral shaping applied as defined by the values of REDUCED_PSD_lowband, PSD level at 1622 kHz, and PSD level at 3750 kHz
REDUCED_PSD_lowband	This 8 bit Npar(3) parameter indicates the relative downstream PSD level that the ATU-R wishes to have applied in the passband below 1104 kHz. It is coded in steps of 0.125dB relative to NOMINAL_PSD_lowband (-40dBm/Hz). For example, 00000000 means -40 dBm/Hz; 00001101 means -41.625 dBm/Hz.
PSD level at 1622 kHz	This 8 bit Npar(3) parameter indicates the relative downstream PSD level that the ATU-R wishes to have applied at 1622 kHz. It is coded in steps of 0.125dB relative to NOMINAL_PSD_lowband (-40dBm/Hz). For example, 00000000 means -40 dBm/Hz; 00001101 means -41.625 dBm/Hz. The PSD level shall be linearly interpolated in dBs between the REDUCED_PSD_lowband level at 1104 kHz and the PSD level at 1622 kHz.

PSD level at 3750 kHz	This 8 bit Npar(3) parameter indicates the relative downstream PSD level that the ATU-R wishes to have applied at 3750 kHz. It is coded in steps of 0.125dB relative to NOMINAL_PSD_lowband (-40dBm/Hz). For example, 00000000 means -40 dBm/Hz; 00001101 means -41.625 dBm/Hz. The PSD level shall be linearly interpolated in dBs between the PSD level at 1622 kHz and the PSD level at 3750 kHz.
-----------------------	--

Q.7.3.2.2 MS messages (supplements 10.3.2)

Table Q.10.

Table Q.10/G.992.1 – ATU-R MS message NPar(2) bit definitions for Annex Q

NSF bit	Definition
G.992.1 Annex Q	If set to ONE, this Spar(1) bit indicates that the ATU-R is selecting G.992.1 Annex Q.
n _{C-PILOT1} =64	If set to ONE, this Npar(2) bit shall indicate that the ATU-R is selecting the pilot tone on subcarrier 64 (Note 1).
n _{C-PILOT1} =128	If set to ONE, this Npar(2) bit shall indicate that the ATU-R is selecting the pilot tone on subcarrier 128 (Note 1).
n _{C-PILOT1} =256	If set to ONE, this Npar(2) bit shall indicate that the ATU-R is selecting the pilot tone on subcarrier 256 (Note 1).
Amateur radio notch – 1.8 MHz band	This selection shall only be performed by the ATU-C. Therefore, this Npar(2) bit shall either be set to the same value as in a previous CL message or set to ONE.
Amateur radio notch – 3.5 MHz band	This selection shall only be performed by the ATU-C. Therefore, this Npar(2) bit shall either be set to the same value as in a previous CL message or set to ONE.
Additional inband spectral shaping	If set to ONE, this Spar(2) bit indicates that the ATU-R is selecting additional downstream inband spectral shaping as defined by the values of REDUCED_PSD_lowband, PSD level at 1622 kHz, and PSD level at 3750 kHz
REDUCED_PSD_lowband	This 8 bit Npar(3) parameter indicates the relative downstream PSD level that the ATU-R wishes to have applied in the passband below 1104 kHz. It is coded in steps of 0.125dB relative to NOMINAL_PSD_lowband (-40dBm/Hz). For example, 00000000 means -40 dBm/Hz; 00001101 means -41.625 dBm/Hz.
PSD level at 1622 kHz	This 8 bit Npar(3) parameter indicates the relative downstream PSD level that the ATU-R wishes to have applied at 1622 kHz. It is coded in steps of 0.125dB relative to NOMINAL_PSD_lowband (-40dBm/Hz). For example, 00000000 means -40 dBm/Hz; 00001101 means -41.625 dBm/Hz. The PSD level shall be linearly interpolated in dBs between the REDUCED_PSD_lowband level at 1104 kHz and the PSD level at 1622 kHz.
PSD level at 3750 kHz	This 8 bit Npar(3) parameter indicates the relative downstream PSD level that the ATU-R wishes to have applied at 3750 kHz. It is coded in steps of 0.125dB relative to NOMINAL_PSD_lowband (-40dBm/Hz). For example, 00000000 means -40 dBm/Hz; 00001101 means -41.625 dBm/Hz. The PSD level shall be linearly interpolated in dBs between the PSD level at 1622 kHz and the PSD level at 3750 kHz.
Note 1: One and only one pilot tone bit shall be set in an MS message.	

Q.7.3.2.3 MP messages (new)

Table Q.11.

Table Q.11/G.992.1 – ATU-R MS message NPar(2) bit definitions for Annex Q

NSF bit	Definition
G.992.1 Annex Q	If set to ONE, this Spar(1) bit indicates that the ATU-R is proposing G.992.1 Annex Q.
$n_{C-PILOT1}=64$	If set to ONE, this Npar(2) bit shall indicate that the ATU-R is proposing the pilot tone on subcarrier 64 (Note 1).
$n_{C-PILOT1}=128$	If set to ONE, this Npar(2) bit shall indicate that the ATU-R is proposing the pilot tone on subcarrier 128 (Note 1).
$n_{C-PILOT1}=256$	If set to ONE, this Npar(2) bit shall indicate that the ATU-R is proposing the pilot tone on subcarrier 256 (Note 1).
Amateur radio notch – 1.8 MHz band	This selection shall only be performed by the ATU-C. Therefore, this Npar(2) bit shall either be set to the same value as in a previous CL message or set to ONE.
Amateur radio notch – 3.5 MHz band	This selection shall only be performed by the ATU-C. Therefore, this Npar(2) bit shall either be set to the same value as in a previous CL message or set to ONE.
Additional inband spectral shaping	If set to ONE, this Spar(2) bit indicates that the ATU-R is proposing additional downstream inband spectral shaping as defined by the values of REDUCED_PSD_lowband, PSD level at 1622 kHz, and PSD level at 3750 kHz
REDUCED_PSD_lowband	This 8 bit Npar(3) parameter indicates the relative downstream PSD level that the ATU-R wishes to have applied in the passband below 1104 kHz. It is coded in steps of 0.125dB relative to NOMINAL_PSD_lowband (–40dBm/Hz). For example, 00000000 means –40 dBm/Hz; 00001101 means –41.625 dBm/Hz.
PSD level at 1622 kHz	This 8 bit Npar(3) parameter indicates the relative downstream PSD level that the ATU-R wishes to have applied at 1622 kHz. It is coded in steps of 0.125dB relative to NOMINAL_PSD_lowband (–40dBm/Hz). For example, 00000000 means –40 dBm/Hz; 00001101 means –41.625 dBm/Hz. The PSD level shall be linearly interpolated in dBs between the REDUCED_PSD_lowband level at 1104 kHz and the PSD level at 1622 kHz.
PSD level at 3750 kHz	This 8 bit Npar(3) parameter indicates the relative downstream PSD level that the ATU-R wishes to have applied at 3750 kHz. It is coded in steps of 0.125dB relative to NOMINAL_PSD_lowband (–40dBm/Hz). For example, 00000000 means –40 dBm/Hz; 00001101 means –41.625 dBm/Hz. The PSD level shall be linearly interpolated in dBs between the PSD level at 1622 kHz and the PSD level at 3750 kHz.
Note 1: More than one pilot tone bit may be set in an MP message.	

Q.7.4 Transceiver Training – ATU-C (supplements 10.4)

During transceiver training from C-REVERB1 to C-SEGUE1 except C-PILOT_n and C-QUIET_n, the ATU-C shall transmit both FEXT_R and NEXT_R symbols when Bitmap-N_R is enabled (Dual Bitmap mode), and shall not transmit the NEXT_R symbols except pilot tone when Bitmap-N_R is disabled (FEXT Bitmap mode). The duration of each state is defined as Figure Q.24.

Q.7.4.1 C-PILOT1 (supplements 10.4.2)

The ATU-C shall start the N_{SWF} (sliding window frame) counter from 0 immediately after entering C-PILOT1, and increment the N_{SWF} counter modulo 345 after transmission of each DMT symbol. According to the sliding window function and this counter, the ATU-C decides to transmit all of the subsequent symbols in either FEXT_R or NEXT_R symbols (for example, see Figures Q.11, Q.17 and Q.22).

C-PILOT1 has two signals.

The first signal is the pilot tone, a single frequency sinusoid at $f_{C-PILOT1}$ defined as:

$$X_k = \begin{cases} 0, & k \neq n_{C-PILOT1}, 0 \leq k \leq NSC \\ A_{C-PILOT1}, & k = n_{C-PILOT1} \end{cases}$$

The frequency of the pilot tone shall be selected from one of the following choices during G.994.1 as:

1. $f_{C-PILOT1} = 276$ kHz ($n_{C-PILOT1} = 64$).
2. $f_{C-PILOT1} = 552$ kHz ($n_{C-PILOT1} = 128$).
3. $f_{C-PILOT1} = 1104$ kHz ($n_{C-PILOT1} = 256$).

The second signal is the TTR indication signal used to transmit $NEXT_R/FEXT_R$ information. The ATU-R can detect the phase information of the TTR_C from this signal. The TTR indication signal shall be selected during G.994.1 as:

A₄₈ signal –the constellation encoding of the 48th carrier with 2-bit constellation as follows:

- (+, +) to indicate a $FEXT_R$ symbol;
- (+, -) to indicate a $NEXT_R$ symbol.

Q.7.4.2 C-PILOT1A (supplements 10.4.3)

C-PILOT1A has two signals and it is the same transmitted signal as C-PILOT1 (C.7.4.1).

Q.7.4.3 C-REVERB3 (supplements 10.4.11)

In order to synchronize the first symbol of C-RATES1 with the beginning of the hyperframe and to inform the entering timing of C-RATES1 to the ATU-R, the first symbol of C-SEGUE1 shall be transmitted inside of the $FEXT_R$ duration as shown in Figure Q.20. Therefore, the duration of C-REVERB3 is 3628 DMT symbols.

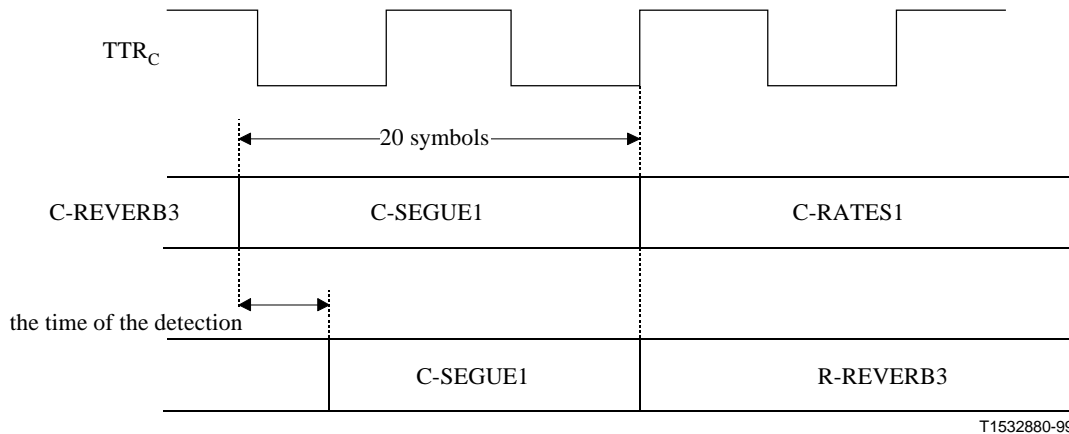

Figure Q.20/G.992.1 – Timing diagram from C-SEGUE1 to C-RATES1

Q.7.4.4 C-REVERB1 (replaces 10.4.5)

C-REVERB1 is a signal that allows the ATU-C and ATU-R receiver to adjust its automatic gain control (AGC) to an appropriate level. The data pattern used in C-REVERB1 shall be the pseudo-random downstream sequence (PRD), d_n for $n = 1$ to $2*NSC$, defined in Q.4.7.5 and repeated here for convenience:

$$\begin{aligned} d_n &= 1 && \text{for } n = 1 \text{ to } 9 && (10-1) \\ d_n &= d_{n-4} \oplus d_{n-9} && \text{for } n = 10 \text{ to } 2*NSC \end{aligned}$$

The bits shall be used as follows: the first pair of bits (d_1 and d_2) is used for the DC and Nyquist subcarriers (the power assigned to them is, of course, zero, so the bits are effectively ignored); then the first and second bits of subsequent pairs are used to define the X_i and Y_i for $i = 1$ to NSC-1 as defined in Table 7-13.

The period of PRD is only 511 bits, so d_{n+511} is equal to d_n . The bits d_1 to d_9 shall be re-initialized for each symbol, so each symbol of C-REVERB1 is identical.

The two bits that modulate the pilot carrier shall be overwritten by {0,0}: generating the {+,+} constellation.

The duration of C-REVERB1 is 512 (repeating) symbols without cyclic prefix.

Q.7.5 Transceiver Training – ATU-R (supplements 10.5)

During transceiver training from R-REVERB1 to R-SEGUE1 except R-QUIETn, the ATU-R shall transmit both FEXT_C and NEXT_C symbols when Bitmap-N_C is enabled (Dual Bitmap mode) and shall not transmit NEXT_C symbols when Bitmap-N_C is disabled (FEXT Bitmap mode). The duration of each state is defined as Figure Q.24.

Q.7.5.1 R-QUIET2 (supplements 10.5.1)

The ATU-R enters R-REVERB1 after it completes timing recovery and Hyperframe synchronization from C-PILOT1/C-PILOT1A.

Q.7.5.2 R-REVERB1 (supplements 10.5.2)

The data pattern used in R-REVERB1 is the pseudo-random upstream sequence PRU defined in 8.11.3 and repeated here for convenience:

$$\begin{cases} d_n = 1 & \text{for } n = 1 \text{ to } 6 \\ d_n = d_{n-5} \oplus d_{n-6} & \text{for } n = 7 \text{ to } 64 \end{cases} \quad (\text{C.10-1})$$

The ATU-R shall start its N_{SWF} counter immediately after entering R-REVERB1, and then increment the N_{SWF} counter with modulo 345 from 0 when it transmits each DMT symbol. The ATU-C and ATU-R shall have the same value since hyperframe alignment between the ATU-C and ATU-R shall be maintained. According to the sliding window and this counter, the ATU-R decides to transmit all of the subsequent symbols in either the FEXT_C or the NEXT_C symbol.

Q.7.5.3 R-QUIET3 (replaces 10.5.3)

The final symbol of R-QUIET3 accommodates the frame alignment of the transmitter to that of the receiver. It may be shortened by any number of samples. The maximum duration of R-QUIET3 is 6145 DMT symbols.

Q.7.5.4 R-REVERB2 (supplements 10.5.5)

After ATU-R detects C-SEGUE1, the ATU-R enters R-SEGUE1. The maximum duration of R-REVERB2 is 3643 DMT symbols.

Q.7.6 Channel analysis (ATU-C) (supplements 10.6)

ATU-C shall transmit only FEXT_R symbols, and shall not transmit the NEXT_R symbols except the pilot tone from C-RATES1 to C-CRC2. During C-MEDLEY, the ATU-C shall transmit both FEXT_R and NEXT_R symbols when Bitmap-N_R is enabled (Dual Bitmap mode). The ATU-C shall not transmit NEXT_R symbols except the pilot tone, when Bitmap-N_R is disabled (FEXT Bitmap mode). The duration of each state is defined in Figure Q.24.

Q.7.6.1 C-SEGUE1 (supplements 10.6.1)

The duration of C-SEGUE1 is 20 symbols in order that the first symbol of C-SEGUE1 shall be inside of the FEXT_R duration.

Q.7.6.2 C-MEDLEY (replaces 10.6.6)

C-MEDLEY is a wideband pseudo-random signal used for estimation at the ATU-R of the downstream SNR. The data to be transmitted are derived from the pseudo-random sequence, PRD, and modulated as defined in 10.4.5. In contrast to C-REVERB1, however, the cyclic prefix is used and the data sequence continues from one symbol to the next (i.e. d_1 to d_9 are not re-initialized for each symbol); since PRD is of length 511, and $2 \times \text{NSC}$ bits are used for each symbol, the subcarrier vector for C-MEDLEY therefore changes from one symbol period to the next. The pilot subcarrier is overwritten by the (+,+) signal constellation. C-MEDLEY is transmitted for 16 384 symbol periods. Following C-MEDLEY the ATU-C shall enter the state C-REVERB4.

Basically, the definition of C-MEDLEY is as given above, except for the duration of the SNR estimation at ATU-R for the downstream. With the periodical noise of TCM-ISDN, SNR also changes in the same cycle, as shown in Figure Q.21. The ATU-C transmits the signal in both of NEXT_R and FEXT_R symbols, and the ATU-R estimates two SNRs from the received NEXT_R and FEXT_R symbols, respectively, as defined in Figure Q.22.

The following formula gives the information that received N_{dmt} -th DMT symbol belongs to:

For $N_{\text{dmt}} = 0, 1, \dots, 344$

$$S = 272 \times N_{\text{dmt}} \bmod 2760$$

if { $(S + 271 < a)$ or $(S > d)$ } then symbol for estimation of FEXT_R SNR

if { $(S > b)$ and $(S + 271 < c)$ } then symbol for estimation of NEXT_R SNR

where $a = 1243$, $b = 1403$, $c = 2613$, $d = 2704$

When Bitmap- N_{R} is disabled (FEXT Bitmap mode), ATU-C shall transmit only the pilot tone as NEXT_R symbol. The number of bits of NEXT_R shall be no more than the number of bits of FEXT_R.

NOTE - At the transmitter, the PRD sequence generator is either always updated or always stopped during NEXT_R symbol when Bitmap- N_{R} is disabled (FEXT Bitmap mode). The receiver should be able to support both modes of transmitter operation.

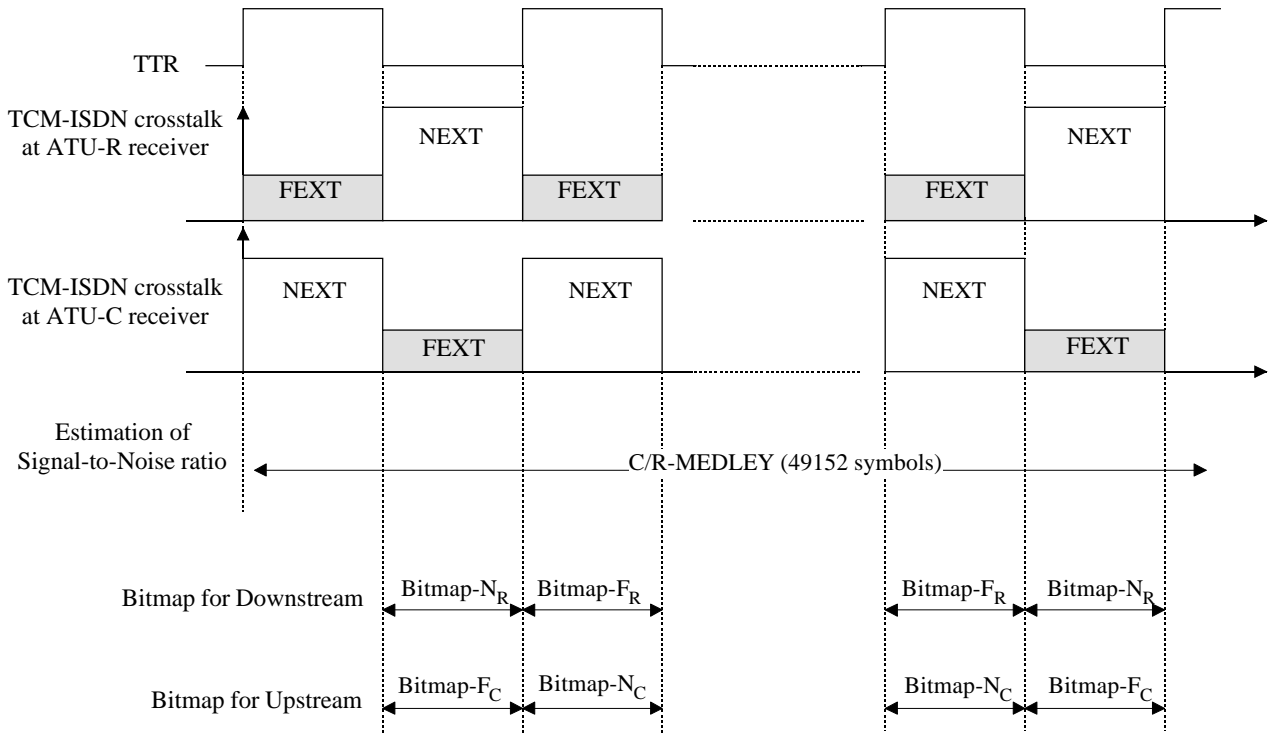

T1532890-99

Figure Q.21/G.992.1 – Estimation of periodic Signal-to-Noise Ratio

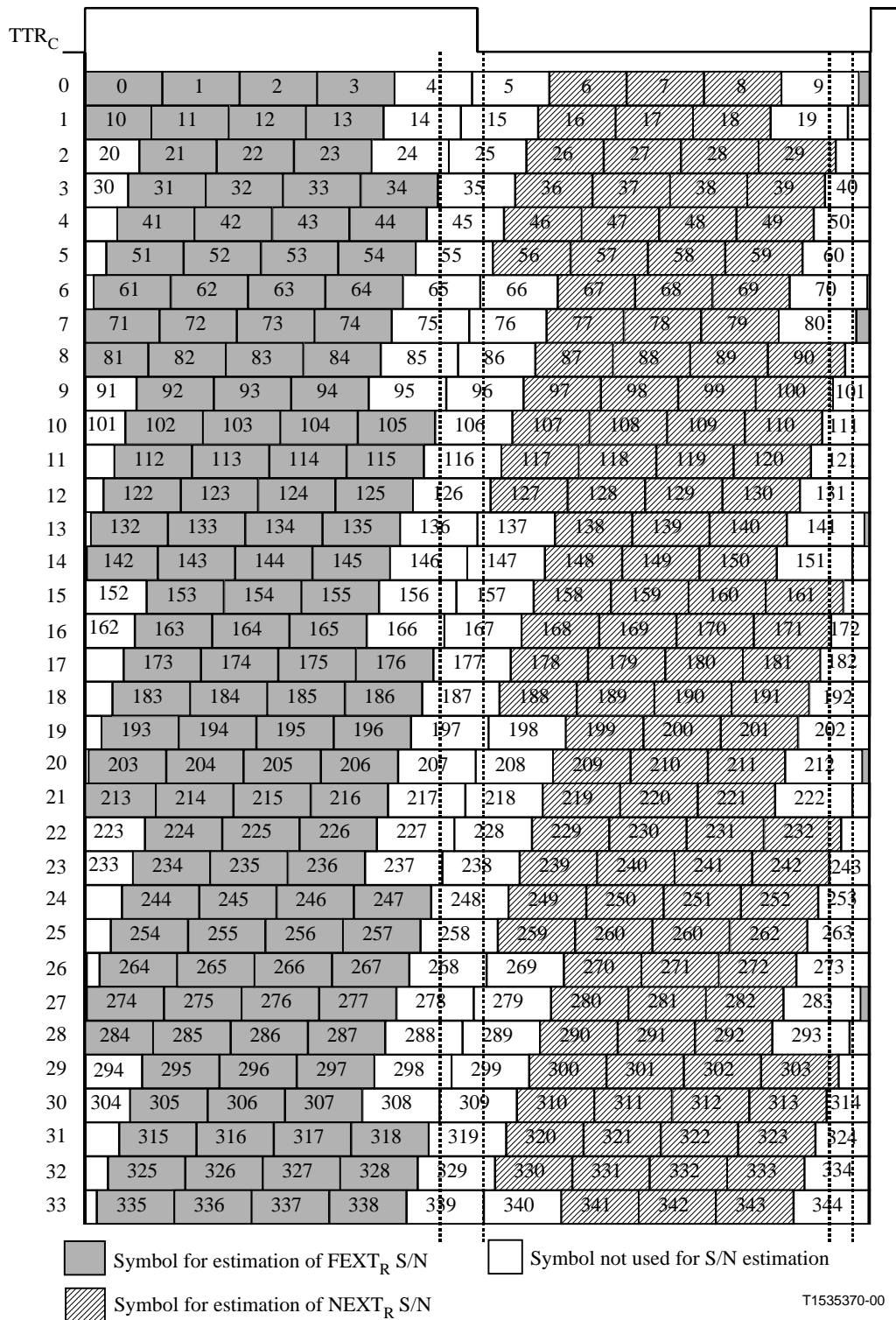

Figure Q.22/G.992.1 – Symbol pattern in a hyperframe for S/N estimation – Downstream

Q.7.6.3 C-RATES1 (supplements 10.6.2)

In order to support data rates greater than 32 Mbit/s, the B_1 field has 11 bits. The RRSI fields shall use the same extended syntax as defined in Q.7.9.4 for C-RATES-RA.

For the $S=1/2n$ framing mode (see §Q.4.9), the downstream RS_1 shall be the number of parity bytes per sync byte, i.e., $RS_1 = R_1/(n*S)$.

Q.7.6.4 C-MSG1 (supplements 10.6.4)

Table Q.12/G.992.1 – Assignment of 48 bits of C-MSG1

Suffix(ces) of m_i (Note 1)	Parameter (Note 3)
47-44	Minimum required downstream SNR margin at initialization (Note 2)
43-18	Reserved for future use
17	Trellis coding option
16	Overlapped spectrum option (Note 4)
15	Unused (shall be set to "1")
14-12	Reserved for future use
11	NTR
10-9	Framing mode
8-6	Transmit PSD during initialization
5	Reserved
4-0	Maximum numbers of bits per subcarrier supported
NOTE 1 – Within the separate fields the least significant bits have the lowest subscripts. NOTE 2 – A positive number of dB; binary coded 0-15 dB. NOTE 3 – All reserved bits shall be set to "0". NOTE 4 – The initialization sequence allows for interworking of overlapped and non-overlapped spectrum implementations. Therefore, this indication is for information only.	

Q.7.6.4.1 Maximum numbers of bits per subcarrier supported – Bits 4-0 (replaces 10.6.4.8)

The N_{downmax} (transmit) capability shall be binary encoded onto $\{m_s, \dots, m_0\}$ (e.g. $10001_2 = 17$). The maximum number of bits for the upstream data, N_{upmax} , that the ATU-C receiver can support need not be signalled to the ATU-R; it will be implicit in the bits and gains message, C-B&G, which is transmitted after channel analysis.

Q.7.7 Channel analysis (ATU-R) (supplements 10.7)

From R-RATES1 to R-CRC2, the ATU-R shall transmit only the $FEXT_C$ symbols and shall not transmit the $NEXT_C$ symbols. In R-SEGUE2 and R-MEDLEY, the ATU-R shall transmit both $FEXT_C$ and $NEXT_C$ symbols when $Bitmap-N_C$ is enabled (Dual Bitmap mode) and shall not transmit $NEXT_C$ symbols when $Bitmap-N_C$ is disabled ($FEXT$ Bitmap mode). The duration of each state is defined in Figure Q.24.

Q.7.8 R-SEGUE1 (supplements 10.7.1)

The maximum duration of R-SEGUE1 is 14 symbols (see Figure Q.20).

Q.7.8.1 R-REVERB3 (supplements 10.7.2)

The ATU-R shall start R-REVERB3 aligned with the beginning of a Hyperframe.

Q.7.8.2 R-SEGUE2 (supplements 10.7.3)

The duration of R-SEGUE2 is 13 symbols.

Q.7.8.3 R-MEDLEY (supplements 10.7.8)

Basically, the definition of R-MEDLEY is the same as 10.7.8, except for the duration of the SNR estimation at ATU-C for the upstream. With the periodical noise of TCM-ISDN, SNR also changes in the same cycle, as shown in Figure Q.21. ATU-R shall transmit the signal in both of $NEXT_C$ and $FEXT_C$ symbols, and ATU-C shall estimate two SNRs from the received $NEXT_C$ and $FEXT_C$ symbols, respectively, as defined in Figure Q.23.

The following numerical formula gives the information that received N_{dmt} -th DMT symbol belongs to:

For $N_{\text{dmt}} = 0, 1, \dots, 344$

$$S = 272 \times N_{\text{dmt}} \bmod 2760$$

if $\{ (S > b) \text{ and } (S + 271 < c) \}$

then symbol for estimation of FEXT_C SNR

if $\{ (S + 271 < a) \}$

then symbol for estimation of NEXT_C SNR

where $a = 1148, b = 1315, c = 2608$

When Bitmap-N_C is disabled (FEXT Bitmap mode), the ATU-R shall not transmit NEXT_C symbol. The number of bits of NEXT_C shall be no more than the number of bits of FEXT_C .

NOTE - At the transmitter, the PRD sequence generator is either always updated or always stopped during NEXT_R symbol when Bitmap-N_R is disabled (FEXT Bitmap mode). The receiver should be able to support both modes of transmitter operation.

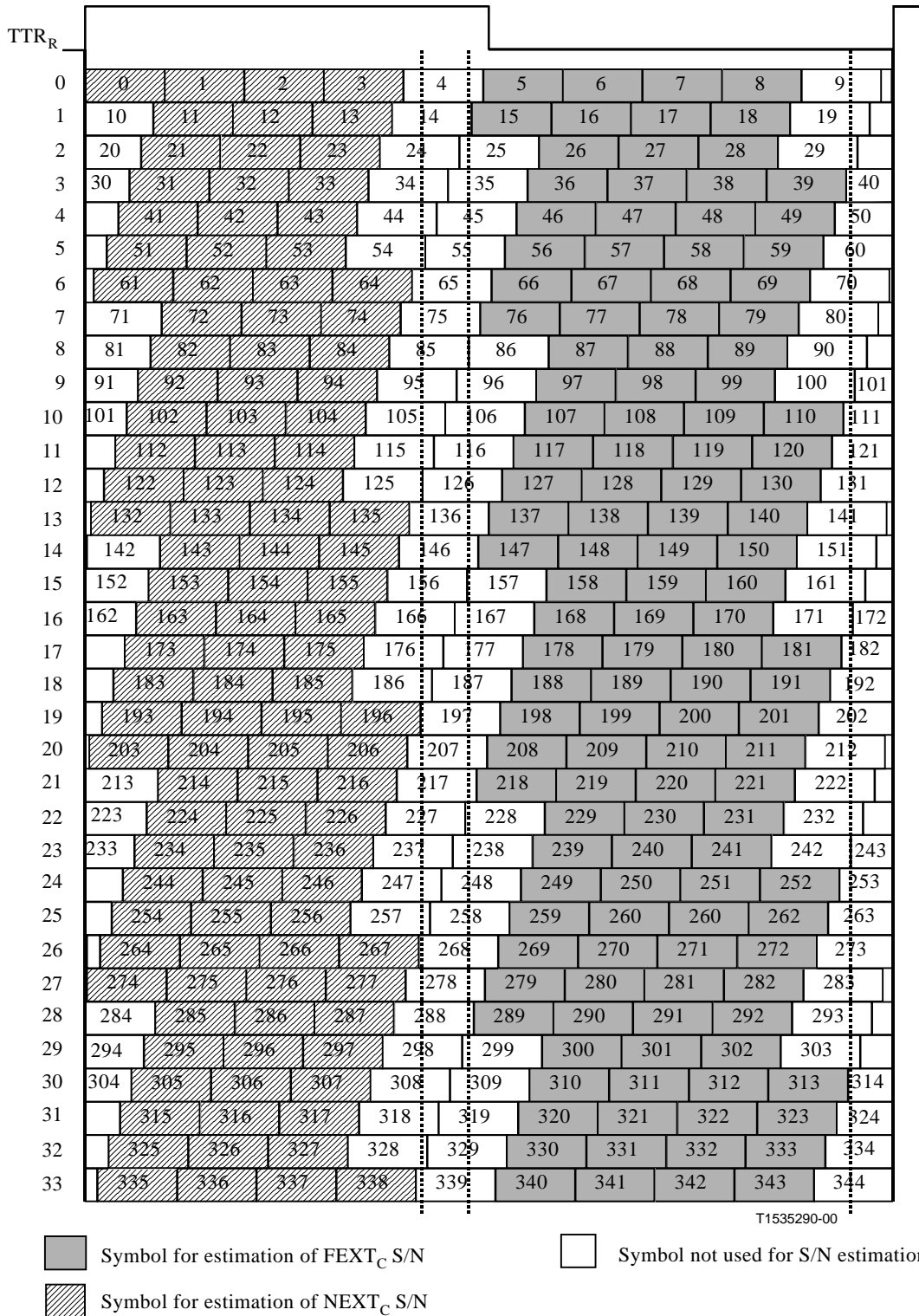

Figure Q.23/G.992.1 – Symbol pattern in a hyperframe for S/N estimation – Upstream

Q.7.8.4 R-MSG1 (supplements 10.7.6)

Table Q.13/G.992.1 – Assignment of 48 bits of R-MSG1

Suffix(ces) of m_i (Note 1)	Parameter (Note 2)
47-18	Reserved for future use
17	Trellis coding option
16	Overlapped spectrum option (Note 3)
15	Unused (shall be set to "1")
14	Support of S = 1/2 mode (see Q.4.9) (Note 4)
13	Support of dual latency downstream
12	Support of dual latency upstream
11	Network Timing Reference
10, 9	Framing mode
8-5	Reserved for future use
4-0	Maximum numbers of bits per subcarrier supported

NOTE 1 – Within the separate fields the least significant bits have the lowest subscripts.
NOTE 2 – All reserved bits shall be set to "0".
NOTE 3 – The initialization sequence allows for interworking of overlapped and non-overlapped spectrum implementations. Therefore, this indication is for information only.
NOTE 4 – Since the S=1/2 mode is mandatory for Annex Q, a modem supporting Annex Q shall set this bit to binary ONE.

Q.7.8.4.1 Maximum numbers of bits per subcarrier supported – Bits 4-0 (replaces 10.7.6.6)

The N_{upmax} (transmit) capability is encoded onto $\{m_4, \dots, m_0\}$ with a conventional binary representation (e.g. $10001_2 = 17$).

Q.7.9 Exchange – ATU-C (supplements 10.8)

During C-RATES_n, C-MSG_n, C-B&G, and C-CRC_n, the ATU-C shall transmit the FEXT_R symbol. In the other signals, the ATU-C shall transmit both FEXT_R and NEXT_R symbols when Bitmap-N_R is enabled (Dual Bitmap mode), and shall not transmit the NEXT_R symbols except pilot tone when Bitmap-N_R is disabled (FEXT Bitmap mode). The duration of each state is defined in Figure Q.25.

Q.7.9.1 C-MSG2 (supplements 10.8.9)

$$n_{1C-MSG2} = 43$$

$$n_{2C-MSG2} = 91$$

Q.7.9.1.1 Total number of bits per symbol supported (supplements 10.8.9.3)

The maximum number of bits per symbol is defined at the reference point B, that is calculated from the FEXT_C and NEXT_C downstream channel performance (e.g. if the maximum numbers of bits that can be supported in FEXT_C and NEXT_C symbols are 111 and 88 {Total number of bits per symbol supported} = $(111 \times 126 + 88 \times 214)/340 = 96$).

NOTE – The number of symbols per hyperframe is 340. The number of FEXT symbols is 126. The number of NEXT symbols is 214.

Q.7.9.2 C-B&G (replaces 10.8.13)

C-B&G shall be used to transmit to the ATU-R the bits and gains information, Bitmap-FC $\{b_1, g_1, b_2, g_2, \dots, b_{31}, g_{31}\}$, and Bitmap-NC $\{b_{33}, g_{33}, b_{34}, g_{34}, \dots, b_{63}, g_{63}\}$, that are to be used on the upstream carriers. b_i of Bitmap-FC indicates the number of bits to be coded by ATU-R transmitter onto the i th upstream carrier in FEXT_C symbols; g_i of Bitmap-FC indicates the scale factor, relative to the gain that was used for that carrier during the transmission of R-MEDLEY, that shall be applied to the i th upstream carrier in FEXT_C symbols. Similarly, b_i of Bitmap-NC indicates the number of bits onto the $(i - 32)$ th upstream carrier in NEXT_C symbols; g_i of Bitmap-NC indicates the scale factor that shall be applied to the $(i - 32)$ th upstream carrier in NEXT_C symbols.

Because no bits or energy will be transmitted at DC or one-half the sampling rate, $b_0, g_0, b_{32}, g_{32}, b_{64},$ and g_{64} are all presumed to be zero and shall not be transmitted.

Each b_i shall be represented as an unsigned 5-bit integer, with valid b_i s lying in the range of zero to N_{upmax} , the maximum number of bits that the ATU-R is prepared to modulate onto any subcarrier, which is communicated in R-MSG1.

Each g_i shall be represented as an unsigned 11-bit fixed-point quantity, with the binary point assumed just to the right of the third most significant bit. For example, a g_i with binary representation (most significant bit listed first)

001.0100000₂ would instruct the ATU-R to scale the constellation for carrier i , by a gain factor of 1.25, so that the power in that carrier shall be 1.94 dB higher than it was during R-MEDLEY.

For subcarriers on which no data are to be transmitted, and the receiver will never allocate bits (e.g. out-of-band subcarriers) both b_i and g_i shall be set to zero (00000₂ and 00000000 000₂, respectively). For subcarriers on which no data are to be currently transmitted, but the receiver may allocate bits later (e.g. as a result of an SNR improvement), the b_i shall be set to zero and the g_i to a value in the 0.19 to 1.33 range (000.00110000₂ to 001.01010101₂).

The C-B&G information shall be mapped in a 992-bit (124 byte) message m defined by:

$$m = \{m_{991}, m_{990}, \dots, m_1, m_0\} = \{g_{63}, b_{63}, \dots, g_{33}, b_{33}, g_{31}, b_{31}, \dots, g_1, b_1\}, \quad (\text{C.10-2})$$

with the MSB of b_i and g_i in the higher m index and m_0 being transmitted first. The message m shall be transmitted in 124 symbols, using the transmission method as described in 10.8.9.

When Bitmap-NC is disabled (FEXT Bitmap mode), b_i and g_i of Bitmap-NC shall be set to zero.

Q.7.9.3 C-SEGUE3 (replaces 10.8.16)

The duration of C-SEGUE3 is 18 symbols. Following C-SEGUE3, the ATU-C completes the initialization and enters C-SHOWTIME. In C-SHOWTIME, ATU-C shall transmit the signal using Bitmap-F_R and Bitmap-N_R with the sliding window.

When Bitmap-N_R is disabled (FEXT Bitmap mode), ATU-C shall transmit only the pilot tone as NEXT_R symbols.

Q.7.9.4 C-RATES-RA (supplements 10.8.3)

Table Q.14/G.992.1 – RRSI fields of C-RATES-RA

	← bits →							
fields	7	6	5	4	3	2	1	0
RS _F	B ₁₀ (AS0)	0	value of RS _F					
			MSB			LSB		
RS _I	B ₈ (AS0)	B ₉ (AS0)	value of RS _I					
			MSB			LSB		
S	I ₉	I ₈	value of S					
			MSB			LSB		
I	I ₇	I ₆	I ₅	I ₄	I ₃	I ₂	I ₁	I ₀
FS(LS2)	value of FS(LS2) set to {00000000 ₂ }							

The RS_I field has been extended to include bit B₉ of B_I (AS0) in bit 6, and The RS_F field has been extended to include the most significant bit B₁₀ of B_I (AS0) in bit 7, B_I (AS0) being the number of payload bytes in the AS0 bearer channel in the downstream interleave buffer. This is to support the higher data rates for the S=1/4, S=1/6 and S=1/8 modes.

The S field shall be coded {100100₂} to indicate S=1/4, {100110₂} to indicate S=1/6, and {101000₂} to indicate S=1/8.

For the S=1/2n framing mode (see §Q.4.9), the downstream RS_I shall be the number of parity bytes per sync byte, i.e., RS_I = R_I/(n*S).

Q.7.10 Exchange – ATU-R (supplements 10.9)

ATU-R shall transmit only the FEXT_C symbols in R-MSG_n, R-RATES_n, R-B&G, R-CRC_n. In other signals, the ATU-R shall transmit both FEXT_C and NEXT_C symbols when Bitmap-N_C is enabled (Dual Bitmap mode) and shall not transmit NEXT_C symbols when Bitmap-N_C is disabled (FEXT Bitmap mode). The duration of each state is defined in Figure Q.25.

Q.7.10.1 R-MSG-RA (supplements 10.9.2)

Replace Table 10-15 with Table Q.15.

Table Q.15/G.992.1 – Assignment of 80 bits of R-MSG-RA (Annex Q)

Suffix(ces) of m_i (Note)	Parameter All reserved bits shall be set to 0
79-72	Reserved for ITU-T
71 - 70	Extension to number of RS payload bytes, K
69, 68	Extension to number of tones carrying data (ncloaded)
67-56	$B_{fast-max}$
55-49	Number of RS overhead bytes, (R)
48-40	Number of RS payload bytes, K
39-32	Number of tones carrying data (ncloaded)
31-25	Estimated average loop attenuation
24-21	Coding gain
20-16	Performance margin with selected rate option
15 - 14	Extension to total number of bits per DMT symbol, B_{max}
13-12	Maximum Interleave Depth
11-0	Total number of bits per DMT symbol, B_{max}
NOTE – Within the separate fields the least significant bits have the lowest subscripts.	

Q.7.10.1.1 Total number of bits supported (B_{max}) (replaces 10.9.2.8)

This parameter shall be defined as in R-MSG2, see Q.7.9.1.

Q.7.10.1.2 $B_{fast-max}$ (new)

$B_{fast-max}$ is the maximum number of bits of the fast buffer for fast data transmitted on the condition that the bits of the fast data can be equally assigned to all FEXT-symbols and NEXT-symbols.

Fast Buffered Data $B_{fast-max}$ is t_f .

Q.7.10.2 R-MSG2 (supplements 10.9.8)

Table Q.16/G.992.1 – Assignment of 32 bits of R-MSG2

Suffix(ces) of m_i (Note 1)	Parameter (Note 2)
31-25	Estimated average loop attenuation
24-21	Reserved for future use
20-16	Performance margin with selected rate option
15 - 14	Extension to total number of bits per DMT symbol, B_{max}
13-12	Reserved for future use
11-0	Total number of bits per DMT symbol, B_{max}
NOTE 1 – Within the separate fields the least significant bits have the lowest subscripts.	
NOTE 2 – All reserved bits shall be set to "0".	

$$N_{1R-MSG2} = 10$$

$$N_{2R-MSG2} = 20$$

Q.7.10.2.1 Total number of bits per symbol supported (supplements 10.9.8.3)

The maximum number of bits per symbol that the downstream channel can support is encoded into bits 15, 14 and 11 – 0.

The maximum number of bits per symbol is defined at the reference point B, that is calculated from the FEXT_R and NEXT_R downstream channel performance. For example, if the maximum numbers of bits that can be supported in FEXT_R and NEXT_R symbols are 111 and 88, the total number of bits per symbol supported is $(111 \times 126 + 88 \times 214)/340 = 96$.

NOTE – The number of symbols per hyperframe is 340, the number of FEXT symbols is 126, and the number of NEXT symbols is 214.

Q.7.10.3 R-B&G (replaces 10.9.14)

The purpose of R-B&G is to transmit to ATU-C the bits and gains information, Bitmap-F_R $\{b_1, g_1, b_2, g_2, \dots, b_{\text{NSC}-1}, g_{\text{NSC}-1}\}$, and Bitmap-N_R $\{b_{\text{NSC}+1}, g_{\text{NSC}+1}, b_{\text{NSC}+2}, g_{\text{NSC}+2}, \dots, b_{2*\text{NSC}-1}, g_{2*\text{NSC}-1}\}$, to be used on the downstream subcarriers. b_i of Bitmap-F_R indicates the number of bits to be coded by ATU-C transmitter onto the i th downstream subcarrier in FEXT_R symbols; g_i of Bitmap-F_R indicates the scale factor that shall be applied to the i th downstream subcarrier in FEXT_R symbols, relative to the gain that was used for that carrier during the transmission of C-MEDLEY. Similarly, b_i of Bitmap-N_R indicates the number of bits onto the $(i - \text{NSC})$ th downstream carrier in NEXT_R symbols; g_i of Bitmap-N_R indicates the scale factor that shall be applied to the $(i - \text{NSC})$ th downstream carrier in NEXT_R symbols. Because no bits or energy will be transmitted at DC or one-half the sampling rate, $b_0, g_0, b_{\text{NSC}}, g_{\text{NSC}}, b_{2*\text{NSC}},$ and $g_{2*\text{NSC}}$ are all presumed to be zero, and are not transmitted. When subcarrier 64 is reserved as the pilot tone, b_{64} and $b_{\text{NSC}+64}$, shall be set to 0, g_{64} and $g_{\text{NSC}+64}$ shall be set to g_{sync} . When subcarrier 128 is reserved as the pilot tone, b_{128} and $b_{\text{NSC}+128}$, shall be set to 0, g_{128} and $g_{\text{NSC}+128}$ shall be set to g_{sync} . The value g_{sync} represents the gain scaling applied to the sync symbol.

Each b_i is represented as an unsigned 5-bit integer, with valid b_i lying in the range of zero to N_{downmax} , the maximum number of bits that the ATU-C is prepared to modulate onto any subcarrier, which is communicated in C-MSG1.

Each g_i is represented as an unsigned 11-bit fixed-point quantity, with the binary point assumed just to the right of the third most significant bit. For example, a g_i with binary representation (most significant bit listed first) 001.0100000₂ would instruct the ATU-C to scale the constellation for carrier i by a gain factor of 1.25, so that the power in that carrier shall be 1.94 dB higher than it was during C-MEDLEY.

For subcarriers on which no data are to be transmitted, and the receiver will never allocate bits (e.g. out-of-band subcarriers) both b_i and g_i shall be set to zero (00000₂ and 00000000 000₂, respectively). For subcarriers on which no data are to be currently transmitted, but the receiver may allocate bits later (e.g. as a result of an SNR improvement), the b_i shall be set to zero and the g_i to a value in the 0.19 to 1.33 range (000.00110000₂ to 001.01010101₂).

The R-B&G information shall be mapped in a $(2*\text{NSC}-2)*16$ -bit $((2*\text{NSC}-2)*2$ byte) message m defined by:

$$m = \{m_{(2*\text{NSC}-2)*16-1}, m_{(2*\text{NSC}-2)*16-2}, \dots, m_1, m_0\} = \{g_{2*\text{NSC}-1}, b_{2*\text{NSC}-1}, \dots, g_{\text{NSC}+1}, b_{\text{NSC}+1}, g_{\text{NSC}-1}, b_{\text{NSC}-1}, \dots, g_1, b_1\}, \quad (\text{Q.10-3})$$

with the MSB of b_i and g_i in the higher m index and m_0 being transmitted first. The message m shall be transmitted in $(2*\text{NSC}-2)*2$ symbols, using the transmission method as described in 10.9.8.

When Bitmap-N_R is disabled (FEXT Bitmap mode), b_i and g_i of Bitmap-N_R shall be set to zero.

Q.7.10.4 R-SEGUE5 (replaces 10.9.17)

The duration of R-SEGUE5 is 13 symbols. Following R-SEGUE-5, ATU-R completes the initialization and enters R-SHOWTIME. In R-SHOWTIME, ATU-R shall transmit the signal using Bitmap-F_C and Bitmap-N_C with the sliding window.

When Bitmap-N_C is disabled (FEXT Bitmap mode), ATU-R shall not transmit NEXT_C symbols.

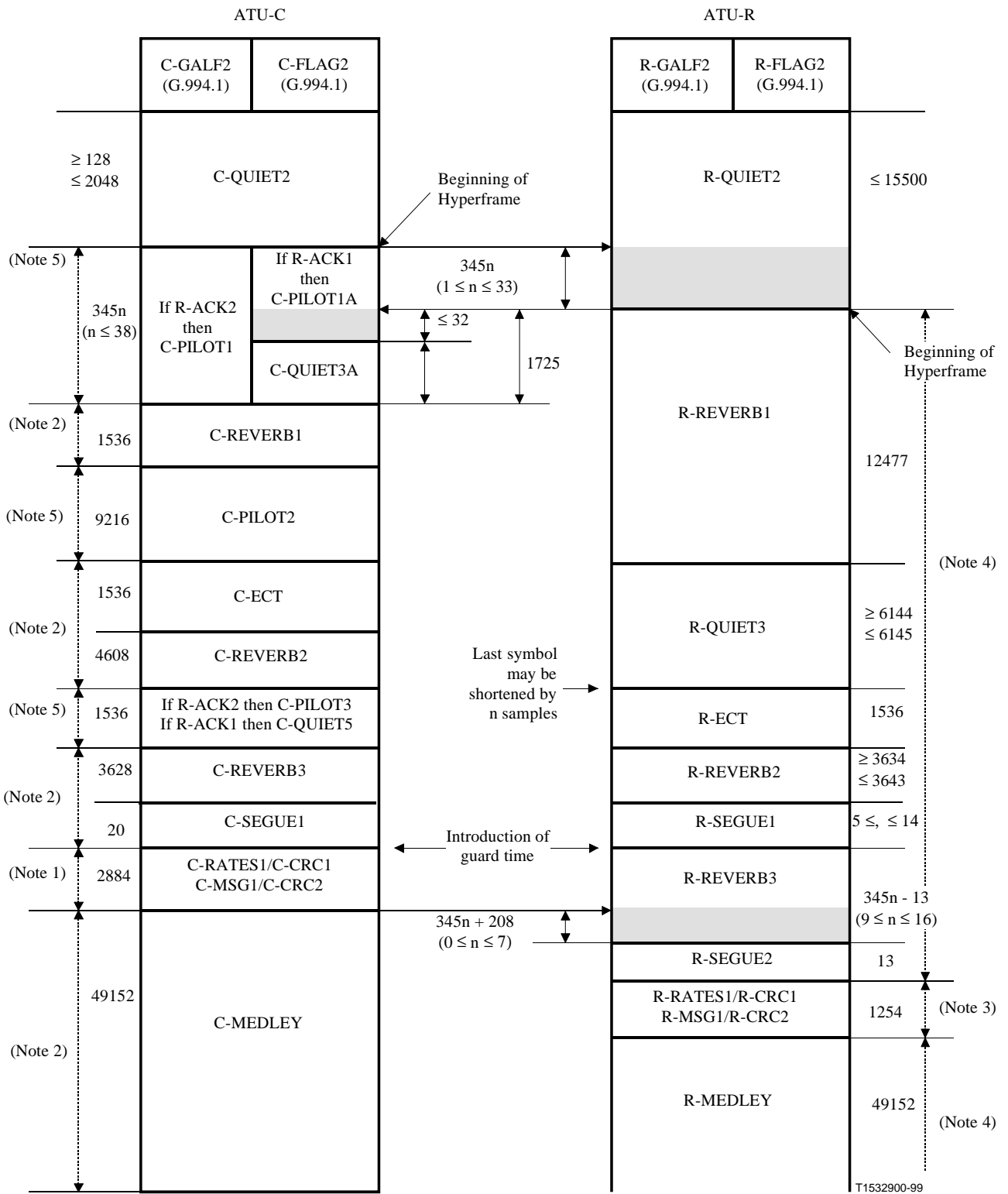
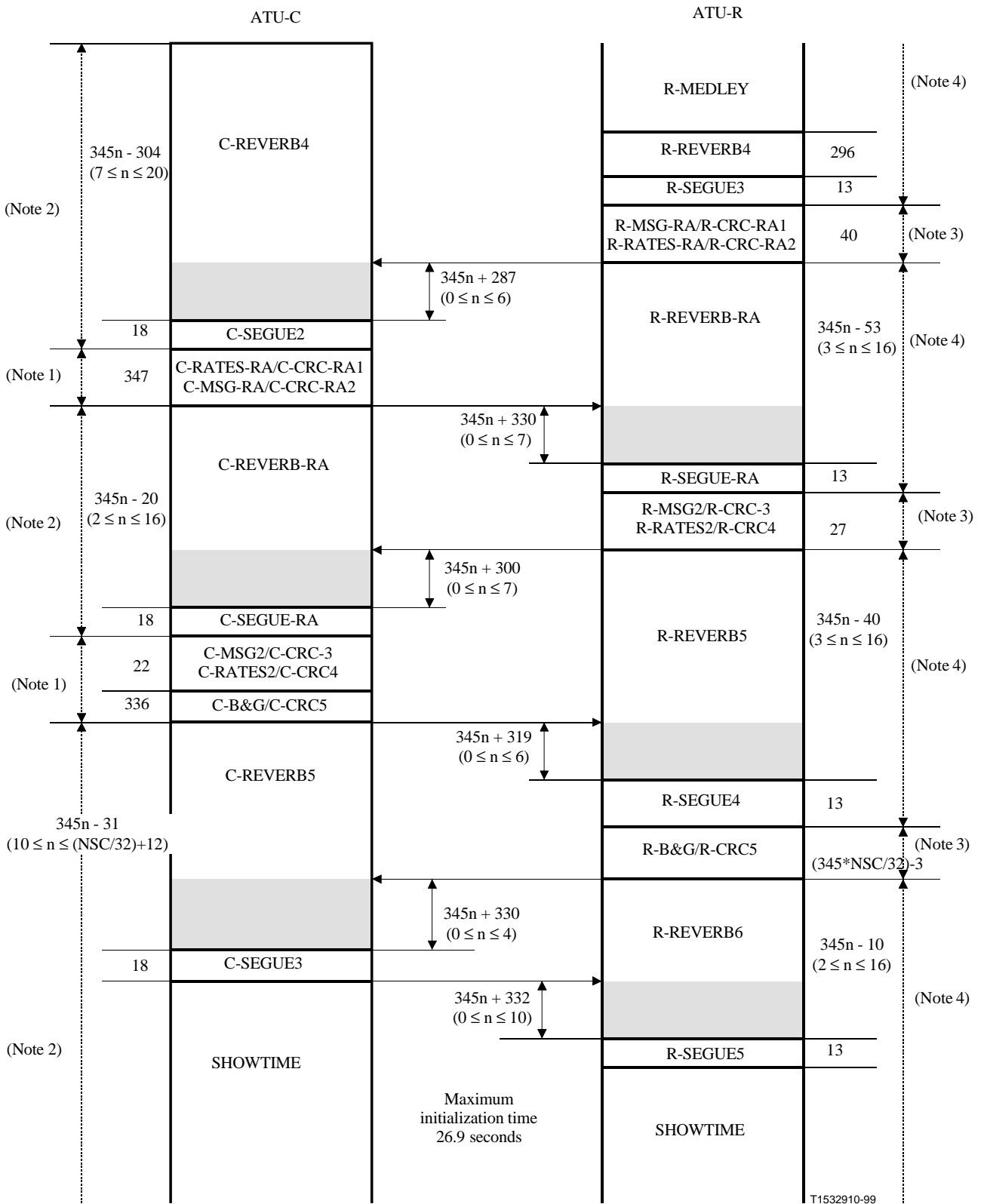

Figure Q.24/G.992.1 – Timing diagram of the initialization sequence – Part 1



NOTE 1 – The ATU-C shall transmit the FEXTR symbols, and shall not transmit as NEXTR symbols except the pilot tone.

NOTE 2 – The ATU-C shall transmit both FEXTR and NEXTR symbols, when Bitmap-NR is enabled (Dual Bitmap mode). ATU-C shall not transmit the NEXTR symbols except pilot tone, when Bitmap-NR is disabled (FEXT Bitmap mode).

NOTE 3 – The ATU-R shall transmit the FEXTC symbols, and shall not transmit the NEXTC symbols.

NOTE 4 – The ATU-R shall transmit both FEXTC symbols, when Bitmap-NC is enabled (Dual Bitmap mode). ATU-R shall not transmit NEXTC symbols, when Bitmap-NC is disabled (FEXT Bitmap mode).

NOTE 5 – The ATU-C shall transmit both FEXTR and NEXTR symbols.

Figure Q.25/G.992.1 – Timing diagram of the initialization sequence – Part 2

Q.8 AOC On-line adaptation and reconfiguration (pertains to clause 11)

Q.8.1.1 Bit swap request (replaces 11.2.3)

The receiver shall initiate a bit swap by sending a bit swap request to the transmitter via the AOC channel. This request tells the transmitter which subcarriers are to be modified. The format of the request is shown in Table Q.17.

Table Q.17/G.992.1 – Format of the bit swap request message

Message header	Message field 1-4			
{11111111} ₂ (8 bits)	Bitmap index (1 bit)	Subchannel index – bits 10 & 9 (2 bits)	Command (5 bits)	Subchannel index – bits 8 to 1 (8 bits)

The request shall comprise nine bytes as follows:

- an AOC message header consisting of 8 binary ones;
- message fields 1-4, each of which consists of a one-bit bitmap index, subchannel index bits 10 & 9, and a five-bit command followed by bits 8 to 1 of the subchannel index. One-bit bitmap index, subchannel index bits 10 & 9, and valid five-bit commands for the bit swap message shall be as shown in Table Q.18. In Table Q.18, the MSB for the bit swap request command represents the Bitmap index. For downstream data, Bitmap index equals 0 indicates Bitmap-F_R, and Bitmap index equals 1 indicates Bitmap-N_R. Similarly for upstream data, Bitmap index equals 0 indicates Bitmap-F_C, and 1 indicates Bitmap-N_C. The next 2 bits are subchannel index bits 10 & 9. The ten-bit subchannel index is counted from low to high frequencies with the lowest frequency subcarrier having the number zero. The subcarrier index zero shall not be used;
- the bit swap between FEXT_{C/R} symbols and NEXT_{C/R} symbols is not allowed.

Table Q.18/G.992.1 – Bit swap request command

Value (8 bit)	Interpretation
yyy00000 ₂	Do nothing
yyy00001 ₂	Increase the number of allocated bits by one
yyy00010 ₂	Decrease the number of allocated bits by one
yyy00011 ₂	Increase the transmitted power by 1 dB
yyy00100 ₂	Increase the transmitted power by 2 dB
yyy00101 ₂	Increase the transmitted power by 3 dB
yyy00110 ₂	Reduce the transmitted power by 1 dB
yyy00111 ₂	Reduce the transmitted power by 2 dB
yyy01xxx ₂	Reserved for vendor discretionary commands
NOTE – y is "0" for FEXT _{C/R} symbols, and "1" for NEXT _{C/R} symbols of the Sliding Window.	
NOTE – subchannel index = yy*256 + subchannel index value from lower 8 bit field	

The bit swap request message (i.e. header and message fields) shall be transmitted five consecutive times.

To avoid g_i divergence between ATU-C and ATU-R after several bit swaps, for a g_i update of Δ dB the new g_i value should be given by:

$$g_i' = (1/256) \times \text{round}(256 \times g_i \times 10^{\Delta/20}) \quad (\text{Q.11-1})$$

Q.8.1.2 Extended bit swap request (supplements 11.2.4)

The format of the extended bit swap request is shown in Table Q.19.

Table Q.19/G.992.1 – Format of the bit swap request message

Message header	Message field 1-6			
{11111100 ₂ } (8 bits)	Bitmap index (1 bit)	Subchannel index – bits 10 & 9 (2 bits)	Command (5 bits)	Subchannel index – bits 8 to 1 (8 bits)

In the same manner as the bit swap request, each of the message fields of the extended bit swap request consists of one-bit bitmap index, a five-bit command followed by a related ten-bit subchannel index.

Q.8.1.3 Bit swap acknowledge (supplements 11.2.5)

The bit swap superframe counter number shall only indicate the last superframe (SPF#4) of a hyperframe.

The new bit and/or transmit power table(s) shall then take effect starting from the first frame (frame 0) of SPF#0 of a hyperframe.

If the bit swap superframe counter number contained in the received bit swap acknowledge message does not indicate SPF#4, then the new table(s) shall take effect starting from frame 0 of SPF#0 of the next hyperframe.